

(19) 日本国特許庁(JP)

(12) 公表特許公報(A)

(11) 特許出願公表番号

特表2004-516880

(P2004-516880A)

(43) 公表日 平成16年6月10日(2004.6.10)

(51) Int.Cl.<sup>7</sup>

A61B 17/22

F I

A 6 1 B 17/22 3 1 0

A 6 1 B 17/22 3 3 0

テーマコード (参考)

4 C 0 6 0

審査請求 未請求 予備審査請求 未請求 (全 87 頁)

(21) 出願番号 特願2002-553990 (P2002-553990)  
 (86) (22) 出願日 平成14年1月7日 (2002.1.7)  
 (85) 翻訳文提出日 平成14年8月30日 (2002.8.30)  
 (86) 国際出願番号 PCT/US2002/000383  
 (87) 国際公開番号 W02002/053037  
 (87) 国際公開日 平成14年7月11日 (2002.7.11)  
 (31) 優先権主張番号 60/260,299  
 (32) 優先日 平成13年1月8日 (2001.1.8)  
 (33) 優先権主張国 米国 (US)

(71) 出願人 500013418  
 ボストン サイエンティフィック リミテッド  
 Boston Scientific Limited  
 バルバドス国 セント マイケル, ベイ  
 ストリート、ブッシュヒル、ザ コーポレ  
 イト センター  
 (74) 代理人 100078282  
 弁理士 山本 秀策  
 (72) 発明者 レイノルズ, ロバート  
 アメリカ合衆国 マサチューセッツ O 1  
 5 3 2, ノースボロ, バックヒル ロ  
 ード 9

最終頁に続く

(54) 【発明の名称】 解放可能なチップを備える回収バスケット

(57) 【要約】

医療用回収デバイスを用いて、患者の身体路（例えば、胆管および膵管、肝管、胆嚢管、総胆管、尿管、膀胱、尿道、ならびに腎臓）から結石（および/または他の物体）を回収および/または断片化する。このデバイスは、解放可能なチップを有する回収バスケットを有する。チップの解放は、制御された予め決定された様式で、および予め決定された力の下で、このデバイスの任意の他の構成要素がバスケットに与えられた力に起因して破損する前に解放されるよう設計されている。

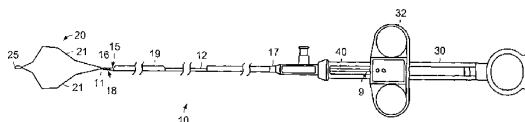

## 【特許請求の範囲】

## 【請求項 1】

医療用デバイスであって、以下：

バスケットであって、複数のワイヤおよび該バスケットの遠位端に配置されるチップジョイントを備える、バスケット、

を備え、該複数のワイヤの各々の端部が、該チップジョイントに固定されており、所定の力が該バスケットに付与される場合に、該複数のワイヤの少なくとも 1 つの端部が該チップジョイントから取り外される、医療用デバイス。

## 【請求項 2】

さらに、以下：

ハンドル；

該ハンドルから遠位方向に延びるシースであって、該シースが、該シースの遠位端から該シースの近位端へと該シースを通して延びる管腔を有する、シース；および

該シースの該管腔内に軸方向に配置される、細長牽引部材であって、該牽引部材が、該ハンドルから遠位方向に延び、そして前記バスケットの近位端に接続される、牽引部材、を備える、請求項 1 に記載のデバイス。

## 【請求項 3】

前記所定の力が、前記牽引部材または前記バスケットの少なくとも 1 つのワイヤを破損させるために必要な力より小さい、請求項 2 に記載のデバイス。

## 【請求項 4】

前記複数のワイヤの端部が、前記チップジョイントにおいて、接着剤によって固定されている、請求項 1 に記載のデバイス。

## 【請求項 5】

前記チップジョイントが、管状チップ部材を備え、該管状チップ部材が、遠位端、近位端、および該管状チップ部材を通して延びる管腔を有し、ここで、該管状チップ部材の該管腔が、前記バスケットワイヤの前記遠位端を内部に受容するよう適合されている、請求項 1 に記載のデバイス。

## 【請求項 6】

前記管状チップ部材の前記管腔が、前記バスケットワイヤの周囲に圧迫されており、これによって該バスケットワイヤを内部に固定する、請求項 5 に記載のデバイス。

## 【請求項 7】

前記所定の力が前記チップジョイントに付与される場合に、前記バスケットを形成する前記複数のワイヤの少なくとも 1 つのワイヤが、前記管状チップ部材からスライドして外れ得る、請求項 5 に記載のデバイス。

## 【請求項 8】

前記牽引部材または前記バスケットを形成する前記複数のワイヤの少なくとも 1 つのワイヤを破損させるために必要とされる力より小さな力で、前記管状チップ部材が変形する、請求項 5 に記載のデバイス。

## 【請求項 9】

前記牽引部材または前記バスケットを形成する前記複数のワイヤの少なくとも 1 つのワイヤを破損させるために必要とされる力より小さな力で変形する材料から、前記管状チップ部材が作製される、請求項 8 に記載のデバイス。

## 【請求項 10】

前記管状チップ部材が、銀ベースの合金、銀、金、白金、ステンレス鋼、およびニッケルチタン合金からなる群より選択される材料から作製される、請求項 8 に記載のデバイス。

## 【請求項 11】

前記管状チップ部材がスターリング銀から作製される、請求項 8 に記載のデバイス。

## 【請求項 12】

前記管状チップ部材がプラスチックから作製される、請求項 8 に記載のデバイス。

## 【請求項 13】

10

20

30

40

50

前記牽引部材または前記バスケットを形成する前記複数のワイヤの少なくとも1つのワイヤを破損させるために必要とされる力より小さな力が、約20ポンド～50ポンドの範囲である、請求項8に記載のデバイス。

【請求項14】

前記牽引部材が、ケーブル、コイル、シャフト、ガイドワイヤ、およびマンドレルワイヤからなる群より選択される、請求項2に記載のデバイス。

【請求項15】

前記牽引部材および前記バスケットが、単一片の材料から形成される、請求項2に記載のデバイス。

【請求項16】

前記バスケットワイヤが、近位コネクタによって前記牽引部材に接合される、請求項2に記載のデバイス。

【請求項17】

前記近位コネクタが、接着ジョイント、ハンダジョイント、溶接ジョイントまたは重ね成形ジョイントからなる群より選択される、請求項16に記載のデバイス。

【請求項18】

前記近位コネクタが、近位管状部材を備え、該近位管状部材が、遠位端、近位端、および該近位管状部材を通して延びる管腔を有し、該近位管状部材の該管腔が、前記バスケットの前記近位端を内部に受容するよう適合されている、請求項16に記載のデバイス。

【請求項19】

前記近位管状部材の前記管腔が、前記バスケットワイヤの周囲で圧迫されており、これによって該バスケットの前記近位端を内部に固定する、請求項18に記載のデバイス。

【請求項20】

前記近位管状部材がステンレス鋼から作製される、請求項19に記載のデバイス。

【請求項21】

前記バスケットが、引込み位置と拡張位置との間で移動可能であり、該引込み位置において、該バスケットは前記シースの前記管腔内で折り畳まれており、そして該拡張位置において、該バスケットは該シースの前記遠位端から伸び、そして身体内の物体を捕獲するために該管腔の外側に配置される、請求項2に記載のデバイス。

【請求項22】

前記拡張位置と前記引込み位置との間での前記バスケットの移動が、前記身体内の前記物体を断片化させる、請求項21に記載のデバイス。

【請求項23】

前記ハンドルが、少なくとも1つの始動機構を内部に備える、請求項2に記載のデバイス。

【請求項24】

前記牽引部材が、前記シースに対してスライド式に移動可能である、請求項2に記載のデバイス。

【請求項25】

前記牽引部材が、前記始動機構に接続されている、請求項23に記載のデバイス。

【請求項26】

前記シースが、前記牽引部材に対してスライド式に移動可能である、請求項2に記載のデバイス。

【請求項27】

前記シースが、前記始動機構に接続されている、請求項23に記載のデバイス。

【請求項28】

前記複数のワイヤがステンレス鋼を含む、請求項1に記載のデバイス。

【請求項29】

前記複数のワイヤがニッケルチタン合金を含む、請求項1に記載のデバイス。

【請求項30】

10

20

30

40

50

前記ハンドルが取り外し可能である、請求項 3 に記載のデバイス。

【請求項 3 1】

前記シースが、内視鏡の作業チャンネル内に嵌合するような寸法にされている、請求項 3 に記載のデバイス。

【請求項 3 2】

身体路から物体を除去するための方法であって、以下の工程：

医療用デバイスを提供する工程であって、該医療用デバイスが、以下：

ハンドル、

該ハンドルから遠位方向に延びるシースであって、該シースが、該シースの遠位端から該シースの近位端へと該シースを通して延びる管腔を有し、該シースが、内視鏡の作業チャンネル内に嵌合するような寸法にされている、シース、

10

バスケットであって、複数のワイヤおよび該バスケットの遠位端に配置されるチップジョイントを備え、該複数のワイヤの各々の端部が、該チップジョイントに固定されており、所定の力が該バスケットに付与される場合に、該複数のワイヤの少なくとも 1 つの端部が該チップジョイントから取り外される、バスケット、

を備える、工程；

該バスケットが引込み位置にある状態で、該医療用デバイスを身体路に導入する工程；

該バスケットを拡張位置にシフトさせる工程；

該バスケットを操作して、該バスケット内に該物体を捕獲する工程；ならびに

該医療用デバイスを該身体路から引抜く工程、

20

を包含する、方法。

【請求項 3 3】

前記医療用デバイスが、前記シースの前記管腔内に軸方向に配置される細長牽引部材をさらに備える、請求項 3 2 に記載の方法。

【請求項 3 4】

前記所定の力が、前記牽引部材または前記バスケットの少なくとも 1 つのワイヤを破損させるために必要とされる力より小さい、請求項 3 3 に記載の方法。

【請求項 3 5】

前記牽引部材に対して近位方向に牽引を付与し、これによって前記バスケット内に張力を発生させ、そして捕獲された前記物体を断片化させる工程をさらに包含する、請求項 3 3 に記載の方法。

30

【請求項 3 6】

前記シースに対して遠位方向に牽引を付与し、これによって前記バスケット内に張力を発生させ、そして捕獲された前記物体を断片化させる工程をさらに包含する、請求項 3 2 に記載の方法。

【請求項 3 7】

X 線透視可視化のための造影剤を注入する工程をさらに包含する、請求項 3 2 に記載の方法。

【請求項 3 8】

身体から物体を除去するための医療用デバイスであって、複数のワイヤおよび遠位端を備えるバスケットを備え、該バスケットに所定の力が付与される場合に該バスケットの遠位端が破損し、ここで、該所定の力が、該医療用デバイスの別の構成要素を破損させるために必要とされる力より小さい、デバイス。

40

【請求項 3 9】

さらに、以下：

ハンドル、

該ハンドルから遠位方向に延びるシースであって、該シースが、該シースの遠位端から該シースの近位端へと該シースを通して延びる管腔を有する、シース、ならびに

該シースの該管腔内に軸方向に配置される、細長牽引部材であって、該牽引部材は、前記ハンドルから遠位方向に延び、そして前記バスケットの近位端に接続されている、細長牽

50

引部材、

を備える、請求項 38 に記載のデバイス。

【請求項 40】

前記所定の力が、前記牽引部材または前記バスケットの少なくとも 1 つのワイヤを破損させるために必要とされる力より小さい、請求項 39 に記載のデバイス。

【請求項 41】

前記バスケットの遠位端がチップ部材を備える、請求項 38 に記載のデバイス。

【請求項 42】

前記所定の力が、前記牽引部材または前記バスケットの少なくとも 1 つのワイヤを破損させるために必要とされる力より小さい、請求項 38 に記載のデバイス。

10

【請求項 43】

前記所定の力が、約 20 ポンド ~ 50 ポンドの範囲である、請求項 38 に記載のデバイス。

【請求項 44】

前記バスケットワイヤが、近位コネクタによって前記牽引部材に接合されている、請求項 39 に記載のデバイス。

【請求項 45】

前記近位コネクタが接着ジョイントを備える、請求項 44 に記載のデバイス。

【請求項 46】

前記近位コネクタがハンダジョイントを備える、請求項 44 に記載のデバイス。

20

【請求項 47】

前記近位コネクタが溶接ジョイントを備える、請求項 44 に記載のデバイス。

【請求項 48】

前記近位コネクタが重ね成形ジョイントを備える、請求項 44 に記載のデバイス。

【請求項 49】

前記近位コネクタが、近位管状部材を備え、該近位管状部材が、遠位端、近位端、および該近位管状部材を通して延びる管腔を有し、該近位管状部材の該管腔が、前記バスケットの前記近位端を内部に受容するよう適合されている、請求項 44 に記載のデバイス。

【請求項 50】

前記近位管状部材の前記管腔が、前記バスケットワイヤの周囲で圧迫されており、これによって該バスケットの前記近位端を該近位管状部材の内部に固定する、請求項 49 に記載のデバイス。

30

【請求項 51】

前記近位管状部材がステンレス鋼から作製される、請求項 50 に記載のデバイス。

【請求項 52】

前記バスケットが、引込み位置と拡張位置との間で移動可能であり、該引込み位置において、該バスケットは前記シースの前記管腔内で折り畳まれており、そして該拡張位置において、該バスケットは該シースの前記遠位端から伸び、そして身体内の前記物体を捕獲するために該管腔の外側に配置される、請求項 39 に記載のデバイス。

【請求項 53】

前記ハンドルが、少なくとも 1 つの始動機構を内部に備える、請求項 39 に記載のデバイス。

40

【請求項 54】

前記牽引部材が、前記シースに対してスライド式に移動可能である、請求項 39 に記載のデバイス。

【請求項 55】

前記牽引部材が、前記始動機構に接続されている、請求項 53 に記載のデバイス。

【請求項 56】

前記シースが、前記牽引部材に対してスライド式に移動可能である、請求項 39 に記載のデバイス。

50

## 【請求項 57】

前記シースが、前記始動機構に接続されている、請求項 53 に記載のデバイス。

## 【請求項 58】

前記複数のワイヤがステンレス鋼を含む、請求項 38 に記載のデバイス。

## 【請求項 59】

前記複数のワイヤがニッケルチタン合金を含む、請求項 38 に記載のデバイス。

## 【請求項 60】

前記ハンドルが取り外し可能である、請求項 40 に記載のデバイス。

## 【請求項 61】

前記シースが、内視鏡の作業チャンネル内に嵌合するような寸法にされている、請求項 40 に記載のデバイス。 10

## 【請求項 62】

身体路から物体を除去するための方法であって、以下の工程：

医療用デバイスを提供する工程であって、該医療用デバイスが、以下：

ハンドル、

該ハンドルから遠位方向に延びるシースであって、該シースが、該シースの遠位端から該シースの近位端へと該シースを通して延びる管腔を有し、該シースが、内視鏡の作業チャンネル内に嵌合するような寸法にされている、シース、

複数のワイヤ、近位端、および遠位端を備えるバスケットであって、所定の力が該バスケットに付与される場合に、該バスケットの遠位端が破損し、ここで、該所定の力が、該医療用デバイスの任意の他の構成要素を破損させるために必要とされる力より小さく、該バスケットが、引込み位置と拡張位置との間で移動可能であり、該引込み位置において、該バスケットは該シースの該管腔内で折り畳まれており、そして該拡張位置において、該バスケットは該シースの該遠位端から伸び、そして身体内の該物体を捕獲するために該管腔の外側に配置される、バスケット、 20

を備える、工程；

該バスケットが引込み位置にある状態で、該医療用デバイスを該身体路に導入する工程；

該バスケットを該拡張位置にシフトさせる工程；

該バスケットを操作して、該バスケット内に該物体を捕獲する工程；ならびに

該医療用デバイスを該身体路から引抜く工程、 30

を包含する、方法。

## 【請求項 63】

前記医療用デバイスが、前記シースの前記管腔内に軸方向に配置される細長牽引部材をさらに備える、請求項 62 に記載の方法。

## 【請求項 64】

前記所定の力が、前記牽引部材または前記バスケットの少なくとも 1 つのワイヤを破損させるために必要とされる力より小さい、請求項 63 に記載の方法。

## 【請求項 65】

前記牽引部材に対して近位方向に牽引を付与し、これによって前記バスケット内に張力を発生させ、そして捕獲された前記物体を断片化させる工程をさらに包含する、請求項 63 に記載の方法。 40

## 【請求項 66】

前記シースに対して遠位方向に牽引を付与し、これによって前記バスケット内に張力を発生させ、そして捕獲された前記物体を断片化させる工程をさらに包含する、請求項 62 に記載の方法。

## 【請求項 67】

X 線透視可視化のための造影剤を注入する工程をさらに包含する、請求項 63 に記載の方法。

## 【請求項 68】

前記複数のワイヤの前記端部が、前記チップジョイントにおいて、ハンダによって固定さ 50

れている、請求項 1 に記載のデバイス。

【請求項 69】

前記複数のワイヤの前記端部が、前記チップジョイントにおいて、溶接によって固定されている、請求項 1 に記載のデバイス。

【請求項 70】

前記複数のワイヤの前記端部が、前記チップジョイントにおいて、重ね成形によって固定されている、請求項 1 に記載のデバイス。

【請求項 71】

前記複数のワイヤの前記端部が、前記チップジョイントにおいて、チップ部材によって固定されている、請求項 1 に記載のデバイス。

10

【請求項 72】

前記バスケットの遠位端がハンダジョイントを備える、請求項 38 に記載のデバイス。

【請求項 73】

前記バスケットの遠位端が溶接ジョイントを備える、請求項 38 に記載のデバイス。

【請求項 74】

前記バスケットの遠位端が重ね成形ジョイントを備える、請求項 38 に記載のデバイス。

【請求項 75】

前記バスケットの遠位端が接着ジョイントを備える、請求項 38 に記載のデバイス。

【発明の詳細な説明】

【0001】

20

(技術分野)

本発明は、一般的に体内の結石のような物質を捕獲するための医療用回収デバイス、および身体路に位置する 1 つ以上の結石を捕獲し、必要に応じてその結石を断片化、粉碎、または解放するバスケットを特徴とする医療用回収デバイスに関する。

【0002】

(発明の背景)

身体路の結石を捕獲するための医療用回収デバイスは、一般的にバスケットを備える。いくつかの医療用回収バスケットはまた、その結石がバスケットに捕獲された後に、大きすぎず身体路からインタクトに除去され得ない結石を必要に応じて粉碎または断片化する機械的碎石器でもある。身体路で結石を粉碎または破壊するための公知のデバイスの 1 つの型は、代表的に内視鏡の作業チャンネルを介してか、またはガイドワイヤにより身体路に導入されるワイヤバスケットを有する。

30

【0003】

機械的な回収のために設計されたバスケットは、代表的にそれらの自然形態が、抑制されない場合、放射線状に外側へ展開するように配置および成形されている複数のワイヤから構築される。このバスケットワイヤは、それらの遠位端および近位端において集められて、バスケットを形成する。細長牽引部材は、代表的にバスケットから、シースを通じてハンドルへと延びている。

【0004】

代表的な回収バスケットは、内視鏡またはカテーテルを介して身体路に導入され、そして結石の周囲で動かされ、その結石をバスケットに入れる。結石の大きさを減少させる必要がある場合、次いで代表的にその結石をバラバラに分解させるのに十分な力がバスケットにより直接的に結石に適用されるまで、結石を取り囲むバスケットワイヤに張力を適用することによって、断片化される。

40

【0005】

体内の結石の大きさ、位置、形状、および組成における機械的な制限および広範なバリエーションは、身体路で結石を回収する際に問題を示す。結石の大きさを減少させるために用いられる方法として、体内または体外から結石に送達される音響ショック波によるか、結石に直接適用されるレーザーエネルギーによるか、または機械的なバスケットにより結石に適用される圧縮力によるような碎石術が挙げられる。機械的バスケット碎石術が、非

50

常に硬い物質からなる結石に試される場合、結石を断片化するために必要とされるバスケットワイヤの張力は、バスケットワイヤ、医療デバイスの種々の接続部、バスケット基部に取り付けられた細長牽引部材、またはシースの強度を超えるかもしれない。身体路の通路が非常に蛇行している場合、身体路における屈曲は、シースの内部表面と牽引部材との直接的な接触の原因となる。牽引部材とシースの間に生じる摩擦は、牽引部材の近位端に適用される張力が、バスケットワイヤに送達される際に大きく減少する原因となる。バスケットワイヤ、このデバイス中の種々の連結部、牽引部材、またはシースの機械的な強度が、中程度の硬さの組成物のみからなる結石を断片化する際にさえも、超過される可能性がある。

**【0006】**

10

結石の捕獲の後の医療用回収デバイス（回収バスケットまたはその構成要素のいずれかを含む）の破損は、バスケットが身体路から取り除かれ得る前に結石の解放を必要とし得る。例えば、医療用デバイスの破損は、牽引部材の近位端付近で生じ得、身体路からバスケットおよび捕獲された結石を除去するためにデバイスの近位端からバスケットを操作するための操作者の能力を損い得る。あるいは、牽引部材は、このデバイスの遠位端で破損し得る。牽引部材の破壊された末端は、身体路から破損したデバイスを除去する試みがなされる場合、身体路の内面を傷つけ得る。1つ以上のバスケットワイヤが破損した場合、バスケットが身体路に導入された同一のルートを通じて、破壊されたバスケットワイヤの断片端で身体路の内面を傷つけることなくバスケットを除去することが不可能であり得る。

**【0007】**

20

大部分の公知の回収バスケットの場合、バスケットを身体路から除去し得るためにバスケットから結石を解放することは困難である。代表的に回収バスケットは、結石を破壊するのに十分な強度を欠く。碎石術を実施するための試みは、回収可能なバスケットまたはその構成要素のいずれかの破損を含む、デバイスの破損を引き起こし得る。結石がバスケットから解放され得ない場合、より侵襲性の外科的な取り組みが、バスケットから結石を解放し、そして身体路からバスケットおよび結石を除去するために必要とされる。

**【0008】**

（発明の要旨）

本発明の目的は、1つ以上の結石および/または他の結石、物体、もしくは他の物質の患者の身体路（例えば、胆管および膵管、肝管、胆嚢管、総胆管、尿管、膀胱、尿道、なら

30

**【0009】**

びに腎臓）からの回収のために有用な医療用デバイスを提供することである。さらに、本発明の目的は、患者の身体路の結石または他の物体を除去前に断片化することが可能な医療用デバイスを提供することである。最終的には、本発明の目的は、回収または断片化された物体から安全に撤退させ、そしてその手順の間にそれらの構成要素のいずれかが破損した場合に、その後安全にデバイスを除去することが可能な医療用デバイスを提供することである。

**【0010】**

従って、この回収デバイスのチップジョイント以外の構成要素の破損を引き起こすのに必要な力の量より少ない力の量がバスケットのワイヤに適用される場合に解放可能である多

40

**【0011】**

ワイヤの回収バスケットを有する医療用デバイスが、本明細書中で開示される。一般的に、1つの局面において、本発明は、ハンドル、シース、およびバスケットを備える医療用デバイスの特徴とする。その中に形成された管腔を有するシースは、ハンドルから遠位に延びている。本発明の1つの実施形態において、このバスケットは、近位端および遠位端を有する複数のワイヤからなる。バスケットワイヤの近位端は、バスケットの基部で連結され、そしてバスケットワイヤの遠位端は、チップジョイントにより解放可能に連結されている。細長牽引部材は、シースの管腔に軸方向に配置され得る。1つの実施形態において、この牽引部材は、ハンドルの近位端から遠位に延びており、そしてバスケット基部に接続されている。この牽引部材は、ケーブル、コイル、シャフト、ガイドワイヤ

50

、またはマンドレルワイヤを備え得る。1つの実施形態において、この牽引部材およびバスケットワイヤは、単一片の材料から形成され得る。別の実施形態において、バスケットワイヤの近位端は、バスケット基部で、近位のコネクタにより牽引部材に連結される。

【0012】

チップジョイントは、予め決定された力（この力は牽引部材または少なくとも1つのバスケットワイヤの破損を引き起こすのに必要な力よりも小さい）がこのチップジョイントに適用される場合、バスケットワイヤの遠位端から解放可能である。

【0013】

本発明のこの局面の実施形態は、以下の特徴を含む。チップジョイントは、接着性のジョイント、はんだ付けのジョイント、溶接ジョイント、または重ね成形（over-molding）ジョイントを含み得る。1つの実施形態において、チップジョイントは、管状チップ部材を含む。この管状のチップ部材の管腔は、その中にバスケットの遠位端を受け入れるよう適合されている。特定の実施形態において、この管状チップ部材の管腔は、バスケットワイヤの周囲で圧縮されており、それによってその中にバスケットの遠位端を固定する。バスケットを形成する複数のワイヤの少なくとも1つのワイヤは、予め決定された力が管状チップ部材に適用される場合、管状チップ部材の中からスライド可能であり、その結果この管状チップ部材が変形する。予め決定された力は、牽引部材またはバスケットを形成する複数のワイヤの少なくとも1つのワイヤの破損を引き起こすのに必要な力よりも小さい。1つの実施形態において、管状チップ部材は、例えば、スターリング銀、銀、金、白金、ステンレス鋼、またはニッケルチタン合金から作製される。他の実施形態において、管状チップ部材はプラスチックから作製される。

10

20

【0014】

本発明の1つの実施形態において、バスケットは、引込み位置（その位置において、バスケットが、シースの管腔内で折り畳まれる）と拡張位置（その位置において、バスケットは、シースの遠位から展開し、そして体内の物体を捕獲するために管腔の外側に配置される）との間を移動可能である。拡張位置と引込み位置との間のバスケットの移動は、バスケット中に捕獲された体内の物体の断片化を引き起こす。

【0015】

本発明の1つの実施形態において、ハンドルは、少なくとも1つの始動機構を備える。特定の実施形態において、牽引部材は、ハンドルの始動機構により作動される場合、シースに対して相対的にスライド移動可能であり、これは、牽引部材が、引込み位置と拡張位置との間でバスケットをシフトすることを引き起こす。

30

【0016】

本発明の別の実施形態において、シースは、牽引部材に対して相対的にスライド移動可能である。この実施形態において、シースは、ハンドルの始動機構に接続されており、これは、シースが、引込み位置と拡張位置との間でバスケットをシフトすることを引き起こす。

【0017】

本発明に従うデバイスのハンドルは、取り外し可能であり得る。1つの実施形態において、シースは、内視鏡の作業チャンネル内に固定されるために、必要な大きさにされる。1つの実施形態において、バスケットを形成する複数のワイヤは、例えば、ステンレス鋼またはニッケルチタン合金から作製される。

40

【0018】

一般的に、別の局面において、本発明は、身体路から物体を除去するための方法の特徴とし、この方法は、上記の医療用デバイスを提供する工程、引込み位置のバスケットを有する医療用デバイスを内視鏡の作業チャンネルに導入する工程；標的の身体路に接近する工程；バスケットを展開された位置にシフトする工程；バスケットを操作して、その中に物体を捕獲する工程；および身体路から医療用デバイスを引き抜く工程、を包含する。本発明のこの局面の特定の実施形態において、この方法は、牽引部材に対して近位方向に牽引を適用し、それによってバスケット内に張力を生じ、そして捕獲された物体の断片化を引き

50

起こす工程をさらに包含する。別の実施形態において、この方法は、シースに対して遠位方向に牽引を適用し、それによってバスケット内に張力を生じ、そして捕獲された物体の断片化を引き起こす工程をさらに包含する。いくつかの実施形態において、この方法はまた、X線透視可視化のために造影剤を注入する工程も包含する。

**【0019】**

(説明)

本発明に従う医療用回収デバイスの以下に開示される実施形態の全ては、一般的に少なくとも1つの事を共通して有し、そしてそれは、多ワイヤ回収バスケットのチップが、チップジョイント以外の回収デバイスの構成要素(例えば、牽引部材)の破損を引き起こすのに必要な一定量の力より少ない一定量の張力が、バスケットのワイヤに適用される場合、解放可能であることである。回収デバイスの1つ以上の構成要素の破損は、この構成要素が、例えば、永久的な変形または破損が原因で、その意図する目的のためにもはや有用でないことを意味する。本発明の回収バスケットは、1つ以上の結石および/または他の結石、物体、または他の物質を身体路(例えば、胆管および膵管、肝管、胆嚢管、総胆管、尿管、膀胱、尿道、ならびに腎臓)から回収するために用いられる。

10

**【0020】**

図1A~1Cを参照すると、本発明に従う医療用デバイス10は、ハンドル30、シース12のようなカテーテル、およびシース12においてスライド移動可能な回収バスケット20を備える。あるいは、回収バスケット20は、定常位置に固定され、シース12がバスケット20を露出させるために(図1A~1B)、およびバスケット20を覆うために/折り畳むために(図1C)スライド移動可能であるように設定され得る。回収バスケット20は、近位のコネクタ16により、1つ以上の細長牽引部材40に可撓的に接続される。あるいは、回収バスケットおよび1つ以上の牽引部材40は、単一片の材料から作製され得る。回収バスケット20は、体内への侵入のためにシース12内で折り畳まれ得る型のバスケットである。一般的に、図1A~1Cに示されるハンドル30、シース12、および回収バスケット20は、それらの正確な大きさまたはお互いの比率で示される必要はない。1つの実施形態において、ハンドル30は、デバイス10全体を分解することなく、デバイス10の残りの部分から取り外し可能であり、そして新しいハンドル30が取り付けられ得る。1つの実施形態において、ハンドルおよびカテーテルアセンブリは、ハンドルシステム(例えば、Boston Scientific Corporation、Natick、Massachusettsにより製造された、Alliance I<sup>T</sup>M Inflation System)と適合し、そしてこのシステムに分解することなく取り付け可能でなければならない。別の実施形態において、バスケットおよび牽引部材は、機械的な碎石システムに適合し、そしてハンドル30およびシース12を除去し、そして碎石システムのハンドルに牽引部材40を取り付けることにより、このシステムに取り付け可能でなければならない。

20

30

**【0021】**

シース12全体の大きさは、体内でのシース12の適用の要求に合うように、必要な大きさにされる。例えば、ほとんどの胆管型の適用にとって、シース12の遠位端15からハンドル30の遠位端17へのデバイス10の作用長は、約60インチ(150cm)から約120インチ(300cm)の範囲であり、好ましくは約70.9インチ(180+/-0.5cm)である。1つの実施形態において、バスケット20およびシース12の大きさは、直径3.2mmまたはそれより大きい内視鏡(例えば、十二指腸鏡)の作業チャンネルに合うように、必要な大きさにされる。

40

**【0022】**

図1B~1Cを参照すると、シース12は、その中に少なくとも1つの管腔14を有し、この管腔は、ハンドル30からシースの遠位端15へと延びている。本発明の1つの実施形態において、シース12は、強化リング(例えば、図1Bおよび図1Cにおいて示されるステンレス鋼強化リング13)により遠位で終結されるワイヤコイルで強化された管を含む。本発明の特定の実施形態において、強化リングは、303ステンレス鋼から作製さ

50

れる。ワイヤコイルは、ステンレス鋼、例えば、304ステンレス鋼から作製され、そしてポリテトラフルオロエチレン（PTFE）でコーティングされて低い摩擦表面を提供する。当業者が理解するように、300シリーズのステンレス鋼は、低い炭素含有量のニッケル-クロムオーステナイト鋼である。特に、303ステンレス鋼は、代表的に17~19%のクロム、8~10%のニッケル、0.15~0.45%の硫黄、0.15%以下の炭素、2%以下のマンガン、0.02%以下のリン、0.6%以下のモリブデン、および1%以下のSiを含み、残りは鉄である。さらに304ステンレス鋼は、代表的に18~20%のクロム、8~10.5%のニッケル、0.03%以下の硫黄、0.08%以下の炭素、2%以下のマンガン、0.45%以下のリン、および1%以下のSiを含み、残りは鉄である。

10

#### 【0023】

デバイス10は、ガイドワイヤ、例えば、Boston Scientific Corporation、Natick、Massachusettsから入手可能な、.035 Jagwire<sup>TM</sup>ガイドワイヤと共に用いられ得る。このような実施形態において、シース12はまた、シース12の遠位端15に配置され、そこから近位へ延びるサイドカー19を備える。サイドカー19は、その中にガイドワイヤを受け入れるよう適合された管腔19aを有する。管腔19aは、ポリテトラフルオロエチレン（PTFE）、ペルフルオロエチレンプロピレン（FEP）、または同様のコーティングでライニングされ得る。サイドカー19の末端は先細にされ、挿管および回収を促進し、周囲の組織に外傷を与えることを避ける。本発明の特定の実施形態において、サイドカー19の管腔19aの直径は、約0.035インチ~約0.040インチの範囲、好ましくは0.038インチであり；そしてサイドカーの長さは、約7インチ~約10インチの範囲、好ましくは8.25インチである。

20

#### 【0024】

細長牽引部材40は、ケーブル、コイル、シャフト、ガイドワイヤ、またはマンドレルワイヤ40であり得、そしてシース12の管腔14内でハンドル30から延びる。特定の実施形態において、牽引部材40は、304ステンレス鋼ワイヤである。1つの実施形態において、牽引部材40は、その近位端9でデバイスハンドル30の少なくとも1つの始動機構32に、そしてその遠位端18で回収バスケット20の基部11に連結されている。別の実施形態において、牽引部材40は、その近位端9でハンドル30に、そしてその遠位端18で回収バスケット20の基部11に連結されている。さらに別の実施形態において、牽引部材40およびバスケットワイヤ21は、単一片の材料から形成される。

30

#### 【0025】

図1Bおよび1Cを参照すると、操作者によるハンドル30での1つ以上の始動機構32の操作は、牽引部材40をシース12においてスライド移動させ、回収バスケット20をシース12の中および外に移動させる。あるいは、この機構32は、シース12が、シース12を静止状態の回収バスケット20および牽引部材40の組合せの上を前進させ、それによってシース12内で回収バスケット20を折り畳み、そして機構32は、移動可能なシース12をスライドさせて戻し、静止状態の回収バスケット20を露出し得、そしてそれが開口/展開するのを可能にする。一般的に、両方の型の回収バスケット/シースの移動構成および関連のハンドル機構が公知であり、そして例えば、Boston Scientific Corporation、Natick、Massachusettsから入手可能な既存の製品設計において見られ得る。

40

#### 【0026】

図1Cに示すように回収バスケット20がシース12内で折り畳まれた状態で、シース12は、操作者により体内に、結石50または回収される結石が位置する体内の部位（例えば、総胆管の結石）に挿入され得る。図1A、1B、および2に示されるように、回収バスケット20をその拡張位置に配置することにより、回収バスケット20は、操作者により操作されて、回収バスケット20内に結石50を閉じ込めるかまたは捕獲し得る。いくつかの臨床的な状況において、捕獲された結石50が断片化されることが望ましい。例え

50

ば、結石50とバスケット20の組合せが、大きすぎて身体路から無傷で回収できない場合、結石50は、例えば、機械的な碎石術により断片化され得る。

【0027】

ここで、図2および3を参照すると、本発明に従って、結石50は、牽引部材40に図2において矢印aにより示される近位方向に牽引を適用することにより、断片化される。ここで図3を参照すると、牽引が牽引部材40に適用される場合、バスケットワイヤ21は、回収バスケット20がシース12に入る場合、結石50の周囲で折り畳まれる傾向がある。漸増量の牽引が牽引部材40に適用される場合、バスケットワイヤ21は、ワイヤ21において生じる張力が結石50を粉碎または断片化するのに十分になるまで結石50の周囲で引き締める。

10

【0028】

図4を参照すると、1つの実施形態において、回収バスケット20は、複数のワイヤ21（例えば、互いに90度の角度で隔離されている4つのワイヤ21a、21b、21c、21d）から構成され、所望のバスケット形状を提供するよう曲げられまたは成形される。1つの実施形態において、このバスケットワイヤ21は、断面が円形、あるいは長方形である。D型またはV型のような他のワイヤの断面形状もまた、本発明により考慮される。1つの実施形態において、各ワイヤ21は4つのベンドを有して形成され、その結果、その拡張位置でのバスケット20の幅は、回収バスケット20の近位端11よりもワイヤ21の遠位端24で大きく、結石50の効果的な捕獲を容易にする。バスケットワイヤ21は、ステンレス鋼、ニッケルチタン、他の金属合金、またはバスケットワイヤに適切な分野で公知の他の物質あるいは物質の組合せから製造され得る。本発明の特定の実施形態において、バスケットワイヤは、54%と57.5%との間のニッケルを含み、残りがチタンである、ニッケルチタン合金から製造される。本発明の1つの実施形態において、バスケットワイヤ21の半径方向への剛性は、0.7g/mmよりも大きい。本発明の別の実施形態において、バスケットワイヤ21の半径方向への剛性は1.0g/mmよりも大きい。

20

【0029】

図4に示される4つのベントワイヤ以外のバスケットワイヤの他の数および他のワイヤ形状もまた、本発明により考慮される。本発明に従う胆管への適用のための回収バスケット20の代表的な寸法は、直径約0.6インチ(1.5cm)×長さ約1.8インチ(3cm)から直径約1.8インチ(3cm)×長さ約2.36インチ(6.0cm)の範囲である。好ましくは、1つの実施形態において、バスケットの寸法は、直径約0.6インチ(1.5cm)×長さ約1.18インチ(3.0cm)、別の実施形態において、直径約0.79インチ(2.0cm)×長さ約1.58インチ(4.0cm)、別の実施形態において、直径約1.0インチ(2.5cm)×長さ約1.97インチ(5.0cm)、およびさらに別の実施形態において直径1.18インチ(3.0cm)×長さ約2.36インチ(6.0cm)である。回収バスケット20の寸法は、体内での回収バスケット20の適用に依存して、より小さくてもより大きくてもよい。例えば、代表的に尿路での適用のために用いられる回収バスケット20の寸法は、胆管での適用のために用いられるバスケットよりも小さくあり得る。

30

40

【0030】

1つの実施形態において、図5Aおよび図5Bに示されるように、例えば、各バスケットワイヤ21は、0.0085インチPRECURSORニッケルチタン合金の3つのフィラメント51a、51b、および51cから製造され、互いにねじられて単一のストランドケーブル21にされる。

【0031】

本発明に従う回収バスケット20により断片化され得る結石50は、大きさにおいて直径約0.2インチ(0.5cm)から直径約1.18インチ(3.0cm)まで変化し得、そして物理的な特性において、コレステロール結石50のような軟質からピリルピン結石50のような硬質まで変化し得る。本発明の1つの実施形態において、回収バスケット2

50

0 は、結石 50 を断片化しない単純な抽出のための、5 つまでの別個の結石 50 を捕獲することが可能な 4 ワイヤバスケットである。1 つの実施形態において、回収バスケット 20 は、回収バスケット 20 に適用される力が、20 ポンドを超えない状況で、結石 50 を断片化しない単純な抽出のための、5 つまでの別個の結石 50 を捕獲することが可能である。別の実施形態において、回収バスケット 20 は、各結石の捕獲の間にハンドルに適用される力が、最小値の 15 ポンドである状況で、結石 50 を断片化しない単純な抽出のための、5 つまでの別個の結石 50 を捕獲することが可能である。

#### 【0032】

1 つの実施形態において、回収バスケット 20 は、各捕獲の間にハンドルに適用される力が 25 ~ 50 ポンドの範囲を超えない状況で、少なくとも 2 つの別個の結石 50 を断片化することが可能である。特定の実施形態において、回収バスケット 20 は、各結石に対して 35 ポンドを超えない力で少なくとも 2 つの別個の結石を断片化することが可能である。別の実施形態において、回収バスケット 20 は、第 1 の結石の断片化の間にハンドルに適用される力が、少なくとも 36 ポンドであり、そして第 2 の結石の断片化の間にハンドルに適用される力が少なくとも 25 ポンドである状況で、少なくとも 2 つの別個の結石 50 を断片化することが可能である。1 つ以上の結石 50 の断片化に続いて、回収バスケット 20 は、シース 12 の管腔 14 において、十分に折り畳まれることが十分可能である。

#### 【0033】

再度、図 4 を参照すると、本発明の 1 つの実施形態において、回収バスケット 20 のバスケットワイヤ 21 a、21 b、21 c、21 d は、例えば、近位のコネクタ 16 により、回収バスケット 20 の基部 11 にてそれらの近位端で連結される。1 つの実施形態において、近位のコネクタ 16 は、長軸方向にそこを通過して延びる管腔を有する管を含む。近位のコネクタ 16 は、ワイヤ 21 a、21 b、21 c、21 d が互いに緊密に保持されるようスエージ加工される。ワイヤ 21 a、21 b、21 c、21 d を連結する当該分野で公知の他の方法（例えば、接着剤、ハンダ付け、溶接、または結合、あるいは近位のコネクタ 16 を有するかまたは有さない任意のそれらの組合せにより）は、バスケット基部 11 でバスケットワイヤ 21 の近位端 52 を連結するか、または集中させるために用いられ得る。本発明の 1 つの実施形態において、近位のコネクタ 16 は、303 ステンレス鋼から作製され、そして 304 ステンレス鋼牽引部材 40 と連結される。

#### 【0034】

図 6 A を参照すると、本発明に従い、バスケットワイヤ 21 の遠位端 24 は、1 点に集中されそしてチップジョイント 25 により適所に保持される。本発明の 1 つの実施形態において、チップジョイント 25 は、例えば、図 6 A および 6 B に示されるような管状チップ部材である。管状チップ部材 25 は、管を通過して長軸方向に延びた管腔 27 を有する管を含む。管状チップ部材 25 は、スターリング銀、コイン銀、または他の銀ベースの合金、純銀、金、白金、ステンレス鋼、ニッケルチタン、他の金属合金、またはプラスチックのような物質から製造され得る。管状チップ部材のための物質は、体内での回収バスケットの適用の要求に合うように選択される。例えば、管状チップ部材 25 が、銀ベースの合金、例えば、銀 / 銅合金から製造される場合、銀の割合が高ければ高いほど、合金の軟らかさが増す。その結果、管状チップ部材 25 は、より低い割合の銀を有する合金から作製された同一のディメンジョンの管状チップ部材よりも小さい解放力でバスケットワイヤ 21 から解放される。1 つの実施形態において、管状チップ部材 25 は、その遠位端 53 でシールされる。

#### 【0035】

図 1 A で示される胆管型の回収バスケット 20 の特定の実施形態において、管状チップ部材 25 は、バスケットワイヤ 21 の遠位端 24 から予め決定された力で解放可能である。図 6 B を参照すると、管状チップ部材 25 は、スターリング銀から製造され得る。管状チップ部材 25 の全体的な長さは 0.123 インチであり、そして最も細い領域 25 a での直径は 0.0510 ~ 0.0520 インチである。管腔 27 の内径は、0.0352 ~ 0.0358 インチである。管腔 27 の長さは、約 0.086 インチである。バスケットワ

10

20

30

40

50

ワイヤ 21 の遠位端 24 は、管状チップ部材 25 の管腔 27 に、0.0545 ~ 0.688 インチ挿入される。最も広い領域 25b での管状チップ部材の直径は、0.085 インチである。管状チップ部材 25 の遠位端 25c は、球状円錐形 (spherico-conical shape) を有し、挿管を容易にし、そして周囲の組織への外傷の危険を減少させる。管状チップ部材 25 の遠位端 25c の半径は、0.030 インチである。

【0036】

図 6A を参照すると、本発明のチップジョイント 25 の 1 つの実施形態において、バスケットワイヤ 21 の遠位端 24 は、管状部材 25 により制御される。というのも、チップ部材 25 は、直径において減少され、すなわち、スエージ加工されて、ワイヤ端 24 を一つに圧縮させるからである。本発明の他の実施形態において、ワイヤ 21 の遠位端 24 は、  
10 接着剤、ハンダ付け、溶接、過剰成形、または他の結合手段により、あるいは管状チップ部材 25 を有するかまたは有さないで、連結方法の任意の組合せにより連結され得る。ワイヤ 21 の遠位端 24 の実施形態の全ては、共通して、予め決定された力がチップジョイント 25 に適用され、チップジョイント 25 がワイヤ 21 から解放される場合に、遠位端 24 が解放可能であるという特徴を有する。

【0037】

図 7A、7B、7C および 7D を参照すると、医療用回収デバイス 10 の構成要素が、身体路内の結石 50 の回収の間に破損する場合に引き起こされる問題を克服するために、本発明に従うチップジョイント 25 は、解放可能なインターフェースを有する。チップジョイント 25 を解放することにより、バスケットワイヤ 21 の遠位端 24 は、解放される、  
20 すなわちもはや一つに連結されない。バスケットワイヤ 21 の遠位端 24 が解放されると、図 7C に示されるように、回収バスケット 20 の遠位端が開口する。この点をより明瞭に説明するために、図 7A を参照して、捕獲された結石 50 を有する回収バスケット 20 は、その展開構成において、シース 12 の遠位端 15 を超えて伸ばされて示される。回収バスケット 20 は、本発明に従う解放可能な管状部材 25 を有する。

【0038】

図 7B を参照すると、牽引が牽引部材 40 に適用される場合、回収バスケット 20 がシース 12 に侵入する場合にバスケットワイヤ 21 は、結石 50 の周囲で折り畳まれる傾向がある。漸増量の牽引が牽引部材 40 に適用される場合、バスケットワイヤ 21 は、結石 50 の周囲を締め付ける。  
30

【0039】

図 7C を参照すると、結石 50 を解放するために、操作者は、矢印 a によって示されるように、牽引部材 40 を近位方向に引くことにより、牽引部材 40 に張力を付与する。バスケットワイヤ 21 がシース 12 の遠位端 15 に入るにつれて、回収バスケット 20 のチップジョイント 25 において、負荷が発生する。この負荷は、1 つ以上のバスケットワイヤ 21 を破損または破壊する負荷よりは小さいが、管状チップ部材 25 の変形を引き起こすには十分である。管状チップ部材 25 が変形する場合に、この部材はバスケットワイヤ 21 の把持を緩め、これによって、バスケットワイヤ 21 の遠位端 24 が管状部材 25 から  
40 スライドして外れることを可能にする。1 つの実施形態において、チップジョイント 25 において回収バスケット 20 を破損させるために必要とされる負荷は、このバスケットチップにおいて約 20 ~ 50 ポンドの範囲である。特定の実施形態において、チップジョイント 25 において回収バスケット 20 を破損させるために必要とされる負荷は、約 42 ポンドである。

【0040】

従って、図 7C に示されるように、バスケットワイヤ 21 の遠位端 24 は、回収バスケット 20 がシース 12 内にさらに引き込まれるにつれて、管状部材 25 からスライドして出る。図 7C に示される結石 50 は、回収バスケット 20 の遠位端を通してバスケットから解放される。図 7D を参照すると、回収バスケット 20 は、バスケットワイヤ 21 の遠位端 24 がシース 12 内に保持されるまで、シース 12 にさらに引き込まれる。バスケットワイヤ 21 がシース 12 によって保持された状態で、医療用回収デバイス 10 は、身体路  
50

から安全に引き抜かれ得る。

【0041】

結石回収の間の過剰負荷条件において、結石50の安全な解放を確実にするために、回収バスケットの遠位チップジョイント25は、デバイス10における任意の他の構成要素（例えば、牽引部材40）を破損させる負荷より小さな負荷で、破損する。遠位チップジョイント25は、デバイス10が意図される作業（すなわち、結石の回収または結石の大きさを減少させること）を実施するために十分に強い。デバイス10の設計は、回収デバイス10の各構成要素およびジョイントの強度の変動を考慮して、チップジョイント25が、デバイス10の他の任意の構成要素またはジョイントが破損するより低い負荷において破損することを、確実にしなければならない。

10

【0042】

図8は、管状チップ部材25のようなチップジョイントによって拘束されたバスケットワイヤ21の遠位端24に対して作用する力の分布を示す。矢印aによって示される、バスケットワイヤ21に対する張力は、矢印bによって示される力の成分B（これは、管状チップ部材25の長軸26と整列する）および矢印cによって示される力の成分C（これは、管状チップ部材25の長軸26に対してほぼ垂直な角度にある）に分解される。チップ部材25の長軸26と整列する、矢印bによって示される力の成分は、管状チップ部材25によってバスケットワイヤ21に対して発生する、矢印eによって示される保持力Eに抵抗される。管状チップ部材25の長軸26と整列した力の成分Bが、利用可能な保持力Eを超える場合には、バスケットワイヤ21は、管状チップ部材25からスライドして外れ、そして結石50を解放する。

20

【0043】

図8において矢印eによって示される、保持力Eは、バスケットワイヤ21と管状チップ部材25との間の摩擦の結果である。バスケットワイヤ21と管状チップ部材25との間の摩擦は、管状チップ部材25によってワイヤ21の遠位端24に及ぼされる圧力、管状チップ部材25の内側の表面の形状、バスケットワイヤ21の外側、管状チップ部材25の物理的寸法、およびバスケットワイヤ21の遠位端24が管状チップ部材25に挿入される距離によって、影響を受ける。矢印cによって示される力の成分C（これは、管状チップ部材25の長軸26に対してほぼ垂直な角度にある）は、管状チップ部材25に作用してバスケットワイヤ21に及ぼされる圧力を低下させ、これによって摩擦を低下させ、そして図8において矢印eによって示される保持力Eを生じる。張力Aが増加するにつれて、管状チップ部材25は変形し始め、その結果、保持力Eが低下する。バスケットワイヤの張力の合成された成分によって、整列した力Bが保持力Eを超え、そしてバスケットワイヤ21に対する全張力負荷がこれらの破壊負荷より小さい場合には、バスケットワイヤ21は、チップジョイント25から解放される。

30

【0044】

管状チップ部材25を解放させるために必要とされる力の量もまた、例えば、チップのクリンプ長を変化させること、このクリンプを含むチップの管状領域の壁の厚みを変化させること、またはバスケットワイヤ21の遠位端24をスコアリングすることによって、変更され得る。

40

【0045】

上記説明は、管状チップ部材25に対するバスケットワイヤ張力の作用を記載するが、バスケットワイヤ21を接合する他の方法を用いて、チップジョイント25に作用する力がバスケットワイヤ21の強度を超えることなくチップジョイント25の強度を超えるような、類似の効果が生じ得る。例えば、バスケットワイヤ21が溶接によって接合される場合には、溶接ジョイント25は、バスケットワイヤ21を破損させるために必要とされる負荷より低い負荷で、破壊するよう設計され得る。溶接は、代表的に、溶接される材料の強度の局所的な低下を引き起こすので、このようなチップジョイント25は、容易に製造され得る。あるいは、バスケットワイヤ21は、接着剤またはハンダによって接合され得、ここで、この接着剤またはハンダ材料の機械的特性は、バスケットワイヤ21の破損負

50

荷より低い負荷で、チップジョイント 25 の破損を可能にする。あるいはなお、バスケットワイヤ 21 は、バスケットワイヤ 21 の遠位端 24 の周囲に、融解可能な材料（例えば、金属もしくは熱可塑性物質）を成形または鑄造することによるか、あるいは硬化可能な液体（例えば、熱硬化性ポリマーまたはエポキシ）を成形することにより、チップジョイント 25 をワイヤの遠位端 24 の周囲に形成することによって、接合され得る。使用される接合の方法および材料は、医療用デバイスの負荷要件によって大きく異なる。例えば、碎石術を伴わない単純な結石回収のために意図された医療用デバイスに関して、シース 12 および回収バスケット 20 は、より軽く、そしてより可撓性の材料で構築されて、結石 50 のより容易な捕獲を可能にする。このようなデバイスを構成する構成要素の強度は、碎石術を意図されたデバイスと比較して低いので、バスケットワイヤ 21 は、接着剤によ

10

#### 【0046】

図 9 は、解放可能なチップジョイント 25 を有する回収バスケット 20 を備える、本発明による医療用回収デバイスの設計理論を示す。曲線 A は、バスケットチップジョイント 25 の破損力の分布を表し、そして曲線 B は、医療用回収デバイス 10 の他の全ての構成要素の破損力の分布を示す。バスケットチップジョイント 25 の破損力の分布は、デバイス 10 の他の全てに対する破損力の分布より十分に低い。従って、バスケットチップジョイント 25 の強度がデバイス 10 の他の任意の構成要素の強度を超える可能性は、きわめて低い。

20

#### 【0047】

本発明の別の局面において、医療用デバイス 10（本発明による回収バスケット 20 を含む）は、身体路から結石 50 を除去するための方法において使用される。この身体路は、身体内の任意の体腔であり得、膵管、胆管（肝管、胆嚢管、および総胆管を含む）、尿管、尿道、膀胱ならびに腎臓が挙げられるが、これらに限定されない。

#### 【0048】

再度、図 1A ~ 1C および 7A ~ 7D を参照すると、本発明のこの局面において、一般に、操作者は、本発明による医療用デバイス 10（回収バスケット 20 を含む）を、内視鏡の作業チャンネルに挿入する。このとき、回収バスケット 20 は、図 1A に示すように、シース 12 内で閉位置にある。あるいは、医療用デバイス 10 は、サイドカー（sidecar）19 を使用して、内視鏡の作業チャンネルを通して、0.035 インチのガイドワイヤ（例えば、Natick Massachusetts の Boston Scientific Corporation により製造される、Jagwire<sup>TM</sup> ガイドワイヤ）の上を通され得る。一旦、このデバイスが目的の身体路に接近すると、代表的に、X 線透視検査の可視化のために、造影剤の注射がなされる。回収バスケット 20 が、捕獲されて断片化されるべき結石 50（単数または複数）に接近する場合に、牽引部材 40 は、遠位（操作者から離れる方向）に進められ、回収バスケット 20 をその拡張配置（ここで、回収バスケット 20 は、もはやシース 12 に拘束されない）に進める。回収バスケット 20 は、シース 12 の遠位端 15 の外側で、その拡張した配置を呈する。次いで、操作者は、結石 50 がバスケットワイヤ 21 の間を通過して回収バスケット 20 に入るまで、拡張した回収バスケット 20 を結石 50 の周囲で操作する。一般に、結石 50 が回収バスケット 20 に捕獲された後に、医療用回収デバイス 10（回収バスケット 20 および捕獲された結石 50 を含む）は、身体路を通して引抜かれる。結石 50 と回収バスケット 20 との組み合わせが、大きすぎて身体路から引抜けない場合には、結石 50 は、大きさが減少されなければならないか、またはバスケット 20 から解放されなければならない。本発明によって、結石 50 の大きさを減少させるためには、結石 50 は、始動機構 32 がバスケット 21 に力を加えて結石 50 の周囲を締め付けることによって、牽引を近位方向に牽引部材 40 に付与することによって、断片化される。牽引部材 40 に付与される力の程度は、結石 50 を断片化させるために十分な張力をバスケットワイヤ 21 内に発生させる程度にまで増加する。碎石術を容易にするためにさらなる張力が必要である場合には、ハンドル 3

30

40

50

0を、Natick MassachusettsのBoston Scientific Corporationにより製造される、Alliance I I<sup>T M</sup> Inflation Systemに取り付け得るか、またはハンドル30およびシース12を取り外し、そして牽引部材40を碎石システムのハンドルに取り付けることによって機械的碎石術システムに取り付け得る。ハンドル30における始動機構32がバスケットワイヤ21に十分な張力を発生させ得ない場合(このとき、例えば、回収バスケット20は、結石50の小さな大きさに起因して、結石50が捕獲される場合にほとんど折り畳まれた位置にある)には、さらなる張力が、必要とされ得る。

#### 【0049】

本発明によれば、結石50を断片化するために必要とされる張力がデバイス10の任意の構成要素を破損させる力に近づく場合に、チップジョイント25が最初に破損する。しかし、いくつかの場合において、牽引部材40が、ハンドル30の遠位端17(ここでは例えば、患者の身体路におけるカテーテルの特定の経路が、牽引部材40の近位端9において増加した摩擦を生じる)において破損し得る。牽引部材40がこのように破損する場合には、ハンドル30およびシース12を取り外し、そして牽引部材40を碎石システムのハンドルに取り付けることによって、機械的碎石システムが牽引部材40に取り付けられ得、結石50を断片化するために必要とされる張力が、医療用デバイス10の任意の構成要素を破損させる力に近づく場合に、バスケットワイヤ21に張力を提供して結石50を断片化させるか、またはチップジョイント25の解放を達成する。

#### 【0050】

本発明の1つの実施形態によれば、チップジョイント25は、図7C~7Dに示されるように、バスケットワイヤ21の遠位端24が管状チップ部材25を解放することによって外れる場合に、破損する。操作者が牽引を牽引部材40に対して近位方向に付与する際に、牽引部材40を介してバスケットワイヤ21に付与される力が、バスケットワイヤ21を破壊するために必要とされる力よりは小さいが管状チップ部材25を変形させるには十分に大きい場合には、管状チップ部材25は、バスケットワイヤ21の遠位端24から解放され、これによって、バスケットワイヤ21が管状チップ部材25からスライドして外れることを可能にする。本発明の1つの実施形態において、チップ部材25をバスケットワイヤ21の遠位端24から解放するために必要とされる力は、バスケットチップにおいて、約20~50ポンドの範囲である。

#### 【0051】

本発明の範囲または意図から逸脱することなく、種々の改変および変更が、上記構造および方法論に対してなされ得ることが、医療用結石除去の分野の当業者に明らかである。

#### 【0052】

図面において、類似の参照文字は一般的に、異なる図を通して同じ部分をいう。図面は、必ずしも同一縮尺ではなく、代わりに本発明の原理を説明する際に一般的に強調がなされる。

#### 【図面の簡単な説明】

##### 【図1A】

図1Aは、バスケットが拡張位置にある、本発明に従う医療用回収デバイスの実施形態を示す。

##### 【図1B】

図1Bは、バスケットが拡張位置にある、図1Aにおいて説明される本発明の実施形態に従うバスケットおよびシースの拡大断面図を示す。

##### 【図1C】

図1Cは、バスケットが引込み位置にある、図1Aにおいて説明される本発明の実施形態に従うバスケットおよびシースの拡大断面図を示す。

##### 【図2】

図2は、捕獲された結石を有し、シースから伸ばされたバスケットを示す。

##### 【図3】

10

20

30

40

50

図 3 は、捕獲された結石を有し、シースの遠位端に部分的に回収されたバスケットを示す。

【図 4】

図 4 は、本発明に従う回収バスケットの実施形態を示す。

【図 5 A】

図 5 A は、本発明の 1 つの実施形態に従うバスケットワイヤの構造の拡大図を示す。

【図 5 B】

図 5 B は、図 5 A に示される本発明の実施形態に従うバスケットワイヤの断面図を示す。

【図 6 A】

図 6 A は、本発明の実施形態に従う回収バスケットのチップジョイントの実施形態を示す 10

【図 6 B】

図 6 B は、図 6 A に示される本発明の実施形態に従う、回収バスケットのチップジョイントの拡大断面図を示す。

【図 7 A】

図 7 A は、本発明に従う回収デバイスから捕獲された結石を解放する工程を示す。

【図 7 B】

図 7 B は、本発明に従う回収デバイスから捕獲された結石を解放する別の工程を示す。

【図 7 C】

図 7 C は、本発明に従う回収デバイスから捕獲された結石を解放する別の工程を示す。 20

【図 7 D】

図 7 D は、本発明に従う回収デバイスから捕獲された結石を解放する別の工程を示す。

【図 8】

図 8 は、本発明に従う回収バスケットのチップジョイントに作用する力を示す。

【図 9】

図 9 は、本発明に従う回収デバイスの他の全ての構成要素についての破損負荷と比較した、チップジョイントについての破損負荷をグラフで示す。

【 図 9 】

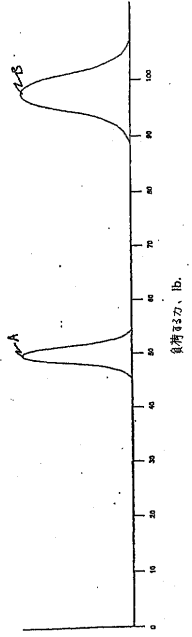

FIG. 9

## 【国際公開パンフレット】

(12) INTERNATIONAL APPLICATION PUBLISHED UNDER THE PATENT COOPERATION TREATY (PCT)

(19) World Intellectual Property Organization  
International Bureau(43) International Publication Date  
11 July 2002 (11.07.2002)

PCT

(10) International Publication Number  
**WO 02/053037 A2**

- (51) International Patent Classification: **A61B 17/00**
- (21) International Application Number: PCT/US02/00383
- (22) International Filing Date: 7 January 2002 (07.01.2002)
- (25) Filing Language: English
- (26) Publication Language: English
- (30) Priority Data:  
60/260,299 8 January 2001 (08.01.2001) US
- (71) Applicant: **SCIMED LIFE SYSTEMS, INC.** [US/US];  
One Scimed Place, Maple Grove, MN 55311-1566 (US).
- (72) Inventors: **REYNOLDS, Robert**; 9 Buckhill Road,  
Northboro, MA 01532 (US). **RICHARDSON, M. Kevin**;  
19 Breakneck Hill Road, Hopkinton, MA 01748 (US).  
**BOWEN, Mark**; 13 Red Acre Road, Stow, MA 01775  
(US).
- (74) Agent: **BELOBORODOV, Mark, L.**; Testa, Hurwitz  
& Thibault, LLP, 11 High Street Tower, 125 High Street,  
Boston, MA 02110 (US).
- (81) Designated States (*national*): AE, AG, AI, AM, AT, AU,  
AZ, BA, BB, BG, BR, BY, BZ, CA, CH, CN, CO, CR, CU,  
CZ, DE, DK, DM, DZ, EC, EE, ES, FI, GB, GD, GE, GH,  
GM, HR, HU, ID, IL, IN, IS, JP, KE, KG, KP, KR, KZ, LC,  
LK, LR, LS, LL, LU, LV, MA, MD, MG, MK, MN, MW,  
MX, MY, NZ, OM, PH, PL, PT, RO, RU, SD, SE, SG,  
SI, SK, SL, TL, TM, TN, TR, TT, TZ, UA, UG, UZ, VN,  
YU, ZA, ZW.
- (84) Designated States (*regional*): ARIPO patent (GH, GM,  
KE, LS, MW, MZ, SD, SL, SZ, TZ, UG, ZM, ZW),  
Eurasian patent (AM, AZ, BY, KG, KZ, MD, RU, TJ, TM),  
European patent (AT, BE, CH, CY, DE, DK, ES, FI, FR,  
GB, GR, IE, IT, LU, MC, NL, PT, SI, TR), OAPI patent  
(BF, BJ, CE, CG, CI, CM, GA, GN, GQ, GW, ML, MR,  
NE, SN, TD, TG).
- Published:**  
*without international search report and to be republished  
upon receipt of that report*
- For two-letter codes and other abbreviations, refer to the "Guidance Notes on Codes and Abbreviations" appearing at the beginning of each regular issue of the PCT Gazette.*



WO 02/053037 A2

(54) Title: RETRIEVAL BASKET WITH RELEASABLE TIP

(57) Abstract: A medical retriever device is used to retrieve and/or fragment stones (and/or other objects) from the body of a patient. The device has a retrieval basket with a releasable tip. The tip release is designed to release in a controlled pre-determined manner and under a pre-determined force before any other component of the device fails due to a force exerted on the basket.

WO 02/053037

PCT/US02/00383

**RETRIEVAL BASKET WITH RELEASABLE TIP**

## TECHNICAL FIELD

[0001] The present invention generally relates to medical retrieval devices for capturing material such as stones within a body and to medical retrieval devices featuring a basket which captures one or more stones located in a body tract and which optionally fragments, crushes, or releases the stones.

## BACKGROUND OF THE INVENTION

[0002] Medical retrieval devices for capturing stones in a body tract generally include a basket. Some medical retrieval baskets are also mechanical lithotriptors which optionally crush or fragment stones that are too large to be removed intact from the body tract after the stone has been captured within the basket. One type of known device for crushing or breaking stones in a body tract has a wire basket that is typically introduced into a body tract via a working channel of an endoscope or by means of a guidewire.

[0003] Baskets designed for mechanical retrieval are typically constructed from a plurality of wires that are arranged and shaped such that their natural form, when unrestrained, is to expand radially outward. The basket wires are gathered together at their distal ends and at their proximal ends to form a basket. An elongated traction member typically extends from the basket through a sheath to a handle.

[0004] A typical retrieval basket is introduced into a body tract via an endoscope or catheter and maneuvered around the stone until the stone enters the basket. If it is necessary to reduce the size of the stone, it is then fragmented typically by applying tension to the basket wires surrounding the stone until sufficient force is applied directly to the stones by the basket wires to cause the stone to break apart.

[0005] Mechanical limitations and wide variation in the size, location, shape, and composition of stones in the body present problems in retrieving stones in a body tract. Methods that are used to reduce the size of the stone include lithotripsy such as by acoustic shock waves delivered to the stone from within or outside the body, laser energy applied directly to the stone, or compressive force applied to the stone by means of a mechanical basket. If mechanical basket

WO 02/053037

PCT/US02/00383

- 2 -

lithotripsy is attempted on a stone composed of very hard material, the basket wire tension required to fragment the stone may exceed the strength of the basket wires, the various connecting joints of the medical device, the elongated traction member attached to the basket base, or the sheath. If the path of the body tract is very tortuous, the bends in the body tract will cause intimate contact of the traction member with the interior surface of the sheath. The friction generated between the traction member and the sheath will cause the tension applied to the proximal end of the traction member to be greatly reduced when delivered to the basket wires. It is possible for the mechanical strength of the basket wires, the various connecting joints in the device, the traction member, or the sheath to be exceeded even when fragmenting stones of only moderately hard composition.

[0006] Failure of the medical retrieval device, including the retrieval basket or any of its components, following capture of a stone may require release of the stone before the basket can be withdrawn from the body tract. Failure of a medical device may occur, for example, near the proximal end of a traction member impairing the ability of the operator to manipulate the basket from the proximal end of the device to remove the basket and captured stone from the body tract. Alternatively, the traction member may fail at the distal end of the device. The broken end of the traction member may traumatize the lining of the body tract if an attempt is made to withdraw the failed device from the body tract. If one or more of the basket wires fail, it may be impossible to remove the basket via the same route by which the basket was introduced into the body tract without traumatizing the lining of the body tract with the fragmented ends of the broken basket wires.

[0007] With most known retrieval baskets, it is difficult to disengage the stone from the basket so that the basket can be removed from the body tract. Retrieval baskets typically lack sufficient strength to break the stone. Attempts to perform lithotripsy may result in failure of the device, including failure of the retrievable basket or any of its components. If the stone can not be released from the basket, more invasive surgical approaches are required to disengage the stone from the basket and to remove the basket and stone from the body tract.

#### SUMMARY OF THE INVENTION

[0008] It is an object of the invention to provide a medical device useful for retrieval of one or more stones and/or other calculi, objects, or other material from a body tract of a patient, such as biliary and pancreatic ducts, hepatic ducts, cystic duct, common bile duct, ureters, urinary bladder, urethra, and kidney.

WO 02/053037

PCT/US02/00383

- 3 -

[0009] Further, it is an object of the invention to provide a medical device capable of fragmenting a stone or other object in a body tract of a patient prior to removal. Finally, it is an object of the invention to provide a medical device capable of safe disengagement from the object being retrieved or fragmented and subsequent safe withdrawal of the device in case of failure of any of the components thereof during the procedure.

[00010] Accordingly, a medical device having a multi-wire retrieval basket which is releasable when an amount of force that is less than the amount of force required to cause failure of components of the retrieval device other than the tip joint is applied to the wires of the basket is disclosed herein.

[00011] In general, in one aspect, the invention features a medical device comprising a handle, a sheath, and a basket. The sheath, having a lumen formed therein, distally extends from the handle. In one embodiment of the invention, the basket consists of a plurality of wires having a proximal end and a distal end. The proximal ends of the basket wires are joined at a basket base and the distal ends of the basket wires are releasably joined by a tip joint. An elongate traction member may be axially disposed within the lumen of the sheath. In one embodiment, the traction member distally extends from the proximal end of the handle and is connected to the basket base. The traction member may comprise a cable, a coil, a shaft, a guidewire or a mandril wire. In one embodiment, the traction member and the basket wires may be formed from a single piece of material. In another embodiment, the proximal ends of the basket wires are joined at the basket base to the traction member by a proximal connector.

[00012] The tip joint is releasable from the distal end of the basket wires when the predetermined force, which is less than the force required to cause the traction member or at least one basket wire to fail, is applied to the tip joint.

[00013] Embodiments of this aspect of the invention include the following features. The tip joint may comprise an adhesive joint, a solder joint, a welded joint or an over-molding joint. In one embodiment, the tip joint comprises a tubular tip member. The lumen of the tubular tip member is adapted to receive the distal end of the basket therein. In a particular embodiment, the lumen of the tubular tip member is compressed around the basket wires thereby securing the distal end of the basket therein. At least one wire of the plurality of wires forming the basket is capable of sliding out of the tubular tip member when the predetermined force is applied to the tubular tip member so that the tubular tip member deforms. The predetermined force is less than the force required to cause the traction member or at least one wire of the plurality of wires

WO 02/053037

PCT/US02/00383

- 4 -

forming the basket to fail. In one embodiment, the tubular tip member is made of, for example, sterling silver, silver, gold, platinum, stainless steel, or a nickel titanium alloy. In other embodiments, the tubular tip member is made of plastics.

5 [00014] In one embodiment of the invention, the basket is moveable between a withdrawn position in which the basket is collapsed within the lumen of the sheath, and an expanded position in which the basket extends from the distal end of the sheath and is disposed outside of the lumen for capturing the objects in the body. Movement of the basket between the expanded position and the withdrawn position causes the objects in the body captured in the basket to fragment.

10 [00015] In one embodiment of the invention, the handle includes at least one actuating mechanism. In a particular embodiment, the traction member is slideably moveable relative to the sheath when actuated by the actuating mechanism in the handle, which causes the traction member to shift the basket between the withdrawn position and the expanded position.

15 [00016] In another embodiment of the invention, the sheath is slideably moveable relative to the traction member. In this embodiment, the sheath is connected to the actuating mechanism at the handle, which causes the sheath to shift the basket between the withdrawn position and the expanded position.

20 [00017] The handle of the device according to the invention may be detachable. In one embodiment, the sheath is dimensioned to fit within a working channel of an endoscope. In one embodiment, the plurality of wires forming the basket is made of, for example, stainless steel or a nickel titanium alloy.

25 [00018] In general, in another aspect, the invention features a method for removing objects from a body tract, including the steps of providing a medical device as described above, introducing the medical device with the basket in the withdrawn position into the working channel of the endoscope; accessing the target body tract; shifting the basket into the expanded position; manipulating the basket to capture the objects therein; and withdrawing the medical device from the body tract. In a particular embodiment of this aspect of the invention, the method further includes the step of applying traction to the traction member in the proximal direction thereby generating tension within the basket and causing the captured objects to  
30 fragment. In another embodiment, the method further includes the step of applying traction to the sheath in the distal direction thereby generating tension within the basket and causing the

WO 02/053037

PCT/US02/00383

- 5 -

captured objects to fragment. In some embodiments, the method also includes the step of injecting contrast material for fluoroscopic visualization.

## BRIEF DESCRIPTION OF THE DRAWINGS

- [00019] In the drawings like reference characters generally refer to the same parts throughout  
5 the different views. The drawings are not necessarily to scale, emphasis instead generally being placed upon illustrating the principles of the invention.
- [00020] FIG. 1A illustrates an embodiment of a medical retrieval device according to the invention with the basket in the expanded position.
- [00021] FIG. 1B illustrates an enlarged cross-sectional view of the basket and the sheath  
10 according to the embodiment of the invention illustrated in FIG. 1A with the basket in the expanded position.
- [00022] FIG. 1C illustrates an enlarged cross-sectional view of the basket and the sheath according to the embodiment of the invention illustrated in FIG. 1A with the basket in the withdrawn position.
- 15 [00023] FIG. 2 illustrates a basket with a captured stone, the basket extended from the sheath.
- [00024] FIG. 3 illustrates a basket with a captured stone, the basket partially withdrawn into the distal end of the sheath.
- [00025] FIG. 4 illustrates an embodiment of a retrieval basket according to the invention.
- [00026] FIG. 5A illustrates an enlarged view of the structure of the basket wire according to  
20 one embodiment of the invention.
- [00027] FIG. 5B illustrates a sectional view of the basket wire according to the embodiment of the invention shown in FIG. 5A.
- [00028] FIG. 6A illustrates an embodiment of the tip joint of the retrieval basket according to the embodiment of the invention.
- 25 [00029] FIG. 6B illustrates an enlarged cross-sectional view of the tip joint of the retrieval basket according to the embodiment invention shown in FIG. 6A
- [00030] FIG. 7A illustrates a step in releasing a captured stone from the retrieval device according to the invention.
- [00031] FIG. 7B illustrates another step in releasing a captured stone from the retrieval device

WO 02/053037

PCT/US02/00383

- 6 -

according to the invention.

[00032] FIG. 7C illustrates another step in releasing a captured stone from the retrieval device according to the invention.

5 [00033] FIG. 7D illustrates another step in releasing a captured stone from the retrieval device according to the invention.

[00034] FIG. 8 illustrates the forces acting on the tip joint of the retrieval basket according to the invention.

[00035] FIG. 9 graphically illustrates failure load for the tip joint compared to failure load for all other components of the retrieval device according to the invention.

10

## DESCRIPTION

[00036] All of the following disclosed embodiments of the medical retrieval device according to the invention generally have at least one thing in common, and that is that the tip of a multi-wire retrieval basket is releasable when an amount of tensile force that is less than the amount of force required to cause failure of components of the retrieval device other than the tip joint, for example, the traction member, is applied to the wires of the basket. Failure of one or more components of the retrieval device means that the component is no longer useful for its intended purpose, because of, for example, permanent deformation or breakage. The retrieval basket of the invention is used to retrieve one or more stones and/or other calculi, objects, or other material from a body tract such as biliary and pancreatic ducts, hepatic ducts, cystic duct, common bile duct, ureters, urinary bladder, urethra, and kidney.

20

[00037] Referring to FIGS. 1A-1C, the medical device 10, according to the invention, includes a handle 30, a catheter, such as a sheath 12, and a retrieval basket 20 slideably moveable in the sheath 12. Alternatively, the retrieval basket 20 can be fixed in a stationary position with the sheath 12 configured to be slideably moveable to expose (FIG. 1A-1B) and cover/collapse (FIG. 1C) the basket 20. The retrieval basket 20 is flexibly connected to one or more elongated traction members 40 by a proximal connector 16. Alternatively, the retrieval basket and one or more traction members 40 can be made from a single piece of material. The retrieval basket 20 is of a type that can be collapsed within a sheath 12 for entry into the body. In general, the handle 30, sheath 12, and retrieval basket 20 illustrated in FIGS. 1A-1C are not necessarily shown in their correct size or proportion to each other. In one embodiment, the handle 30 is detachable from the rest of device 10 without disassembly of the entire device 10,

25

30

WO 02/053037

PCT/US02/00383

- 7 -

and a new handle 30 may be attached. In one embodiment, the handle and catheter assembly must be compatible with and attachable to a handle system, such as Alliance II™ Inflation System, manufactured by Boston Scientific Corporation of Natick, Massachusetts, without disassembly. In another embodiment, the basket and the traction member must be compatible

5 with and attachable to a mechanical lithotripsy system by removing the handle 30 and the sheath 12, and attaching the traction member 40 to the handle of the lithotripsy system.

[00038] The size of the entire sheath 12 is dimensioned to fit the requirements of the application of the sheath 12 in the body. For example, for most biliary type applications, the working length of the device 10 from the distal end 15 of the sheath 12 to the distal end 17 of the handle 30 ranges from about 60 inches (150 cm) to about 120 inches (300 cm), preferably about 10 70.9 inches (180+/- 0.5 cm). In one embodiment, the size of the basket 20 and sheath 12 is dimensioned to fit in a 3.2 mm diameter or larger working channel of an endoscope, such as duodenoscope.

[00039] Referring to FIGS. 1B-1C, the sheath 12 has at least one lumen 14 therein that 15 extends from the handle 30 to the distal end of the sheath 15. In one embodiment of the invention, the sheath 12 includes a wire coil reinforced tube terminated distally by a reinforcement ring, such as a stainless steel reinforcement ring 13 illustrated in FIGS. 1B and 1C. In a particular embodiment of the invention, the reinforcement ring is made of 303 stainless 20 steel. The wire coil is made of stainless steel, for example, 304 stainless steel, and is coated with polytetrafluoroethylene (PTFE) to provide a low friction surface. As one of ordinary skill would appreciate, the 300 series stainless steels are nickel-chromium austenitic steels with low carbon content. Particularly, 303 stainless steel typically contains 17-19% chromium, 8-10% nickel, .15-.45% sulfur, no more than .15% carbon, no more than 2% manganese, no more than .02% phosphorus, no more than .6% molybdenum, and no more than 1% Si with balance iron. 25 Further, 304 stainless steel typically contains 18-20% chromium, 8-10.5% nickel, no more than .03% sulfur, no more than .08% carbon, no more than 2% manganese, no more than .45% phosphorus, and no more than 1% Si with balance iron.

[00040] The device 10 can be used in conjunction with a guidewire, such as, for example, a .035 Jagwire™ guidewire available from Boston Scientific Corporation of Natick, 30 Massachusetts. In such embodiment, the sheath 12 also includes a sidecar 19 located at the distal end 15 of the sheath 12 extending proximally therefrom. The sidecar 19 has a lumen 19a therein adapted to receive a guidewire. The lumen 19a may be lined with polytetrafluoroethylene

WO 02/053037

PCT/US02/00383

- 8 -

(PTFE), perfluoroethylenepropylene (FEP), or similar coating. The ends of the sidecar 19 are tapered to promote cannulation and withdrawal and to avoid inflicting trauma to surrounding tissues. In a particular embodiment of the invention, the diameter of the lumen 19a of the sidecar 19 is in the range of about .035 inches to .040 inches, preferably 0.038 inches; and the length of the sidecar is in the range of about 7 inches to about 10 inches, preferably 8.25 inches.

5 [00041] An elongated traction member 40 can be a cable, coil, shaft, guidewire or mandril wire 40 and extends within the lumen 14 of the sheath 12 from the handle 30. In a particular embodiment, the traction member 40 is a 304 stainless steel wire. In one embodiment, the traction member 40 is joined at its proximal end 9 to at least one actuating mechanism 32 at the device handle 30 and at its distal end 18 to the base 11 of the retrieval basket 20. In another 10 embodiment, the traction member 40 is joined at its proximal end 9 to handle 30, and at its distal end 18 to the base 11 of the retrieval basket 20. In yet another embodiment, the traction member 40 and the basket wires 21 are formed from a single piece of material.

15 [00042] Referring to FIGS. 1B and 1C, operation of one or more actuating mechanisms 32 on the handle 30 by an operator causes the traction member 40 to slideably move in the sheath 12 causing the retrieval basket 20 to move in and out of the sheath 12. Alternatively, the mechanism 32 can cause movement of the sheath 12 to advance the sheath 12 over the stationary retrieval basket 20 and traction member 40 combination to thereby collapse the retrieval basket 20 within the sheath 12, and the mechanism 32 can slide the moveable sheath 12 back to expose 20 the stationary retrieval basket 20 and allow it to open/expand. In general, both types of retrieval basket /sheath movement configurations and related handle mechanisms are known, and can be seen in existing product designs available from, for example, Boston Scientific Corporation of Natick, Massachusetts.

25 [00043] With the retrieval basket 20 collapsed within the sheath 12 as shown in FIG. 1C, the sheath 12 can be inserted into the body by an operator to a site in the body where the stone 50 or stones to be retrieved are located (e.g., a stone in the common bile duct). By placing the retrieval basket 20 into its expanded position, as illustrated in FIGS. 1A, 1B, and 2, the retrieval basket 20 can be manipulated by the operator to entrap or capture a stone 50 within the retrieval basket 20. In some clinical situations it is desirable to fragment the captured stone(s) 50. For example, 30 when the combination of the stone 50 and basket 20 is too large to be withdrawn atraumatically from the body tract, the stone 50 may be fragmented by, for example, mechanical lithotripsy.

[00044] Referring now to FIGS. 2 and 3, according to the invention, stone 50 is fragmented

WO 02/053037

PCT/US02/00383

- 9 -

by applying traction on the traction member 40 in a proximal direction indicated by arrow *a* in FIG. 2. Referring now to FIG. 3, as traction is applied to traction member 40, the basket wires 21 tend to collapse around the stone 50 as the retrieval basket 20 enters the sheath 12. As an increasing amount of traction is applied to the traction member 40, the basket wires 21 tighten  
5 around the stone 50 until the tension generated in the wires 21 is sufficient to crush or fragment the stone 50.

[00045] Referring to FIG. 4, in one embodiment, the retrieval basket 20 is composed of a plurality of wires 21, such as four wires 21a, 21b, 21c, 21d spaced at 90 degree angle apart from each other that are bent or formed to provide the desired basket shape. The basket wires 21 in  
10 one embodiment are round, or alternatively, rectangular in cross section. Other cross-sectional wire shapes are also contemplated by the invention, such as D-shaped or V-shaped. In one embodiment, each of wires 21 is formed with four bends so that the width of the basket 20 in its expanded position is greater at the distal end 24 of the wires 21 than at the proximal end 11 of the retrieval basket 20 to ease effective capture of stones 50. The basket wires 21 may be  
15 manufactured from stainless steel, nickel titanium, other metal alloys, or other materials or combinations of materials known in the art suitable for basket wires. In a particular embodiment of the invention, the basket wires are manufactured from a nickel-titanium alloy containing between 54% and 57.5% nickel with balance titanium. In one embodiment of the invention, the radial stiffness of the basket wires 21 is greater than .7 g/mm. In another embodiment of the  
20 invention the radial stiffness of the basket wires 21 is greater than 1.0 g/mm.

[00046] Other numbers of basket wires and other wire shapes are also contemplated by the invention other than the four bent wires illustrated in FIG. 4. The typical dimensions for a retrieval basket 20 for biliary applications, according to the invention, range from about 0.6 inches (1.5 cm) in diameter by about 1.8 inches (3 cm) in length to about 1.8 inches (3 cm) in  
25 diameter by about 2.36 inches (6.0 cm) in length. Preferably, the basket dimensions in one embodiment are about 0.6 inches (1.5 cm) in diameter by about 1.18 inches (3.0 cm) in length, in another embodiment, about 0.79 inches (2.0 cm) in diameter by about 1.58 inches (4.0cm) in length, in another embodiment, about 1.0 inch (2.5 cm) in diameter by about 1.97 inches (5.0 cm) in length, and in yet another embodiment, 1.18 inches (3.0 cm) in diameter by about 2.36  
30 inches (6.0 cm) in length. The dimensions of the retrieval basket 20 may be smaller or larger depending on the application of the retrieval basket 20 in the body. For example, the dimensions of the retrieval basket 20 used for typical urinary tract applications may be smaller than the

WO 02/053037

PCT/US02/00383

- 10 -

basket used for biliary applications.

[00047] In one embodiment, illustrated in FIGS. 5A and 5B, for example, each of the basket wires 21 are manufactured from three filaments 51a, 51b, and 51c of 0.0085 inch PRECURSOR nickel titanium alloy twisted together into a single stranded cable 21.

5 [00048] The stones 50 that may be fragmented by the retrieval basket 20 according to the invention may vary in size from about 0.2 inches (0.5 cm) in diameter up to about 1.18 inches (3.0 cm) in diameter and vary in physical characteristics as soft, such as cholesterol stones 50, to hard, such as bilirubin stones 50. In one embodiment of the invention, the retrieval basket 20 is a four-wire basket capable of capturing up to five separate stones 50 for simple extraction without  
10 fragmenting the stones 50. In one embodiment, the retrieval basket 20 is capable of capturing up to five separate stones 50 for simple extraction without fragmenting the stones 50 where the force applied to the retrieval basket 20 does not exceed 20 pounds. In another embodiment, the retrieval basket 20 is capable of capturing up to five separate stones 50 for simple extraction without fragmenting the stones 50 where the force applied to the handle during each stone  
15 capture is a minimum of 15 pounds.

[00049] In one embodiment, the retrieval basket 20 is capable of fragmenting at least two separate stones 50 where the force applied to the handle during each capture does not exceed the range of 25-50 pounds. In a particular embodiment, the retrieval basket 20 is capable of fragmenting at least two stones at a force that does not exceed 35 pounds for either stone. In  
20 another embodiment, the retrieval basket 20 is capable of fragmenting at least two separate stones 50 where the force applied to the handle during fragmenting of a first stone is at least 36 pounds, and the force applied to the handle during fragmenting of a second stone is at least 25 pounds. Following fragmentation of one or more stones 50, the retrieval basket 20 is fully capable of being fully collapsed in the lumen 14 of the sheath 12.

25 [00050] Referring again to FIG. 4, in one embodiment of the invention, the basket wires 21a, 21b, 21c, 21d of the retrieval basket 20 are joined at their proximal ends at the base 11 of the retrieval basket 20 by, for example, a proximal connector 16. In one embodiment, the proximal connector 16 comprises a tube having a lumen extending longitudinally therethrough. The proximal connector 16 is swaged to hold the wires 21a, 21b, 21c, 21d together tightly. Other  
30 methods of joining the wires 21a, 21b, 21c, 21d known in the art such as adhesives, solder, welding, or binding, or by any of their combination with or without proximal connector 16 may be used to join or gather together the proximal ends 52 of basket wires 21 at the basket base 11.

WO 02/053037

PCT/US02/00383

- 11 -

In one embodiment of the invention, the proximal connector 16 is made of 303 stainless steel and is joined to a 304 stainless steel traction member 40.

[00051] Referring now to FIG. 6A, according to the invention, the distal ends 24 of the basket wires 21 are gathered together and held in place by a tip joint 25. In one embodiment of the invention, tip joint 25 is a tubular tip member, for example, as illustrated in FIG. 6A and 6B. The tubular tip member 25 comprises a tube having a lumen 27 extending longitudinally through the tube. The tubular tip member 25 may be manufactured from materials such as sterling silver, coin silver or other silver-based alloys, pure silver, gold, platinum, stainless steel, nickel titanium, other metal alloys, or plastics. The material for the tubular tip member is chosen to fit the requirements of the application of the retrieval basket in the body. For example, if the tubular tip member 25 is manufactured from a silver-based alloy, for example silver/copper alloy, a higher percentage of silver would result in a softer alloy. As a result, the tubular tip member 25 will release from the basket wires 21 at a release force that is lower than that of the tubular tip member of identical dimensions made from an alloy with a lower percentage of silver. In one embodiment, the tubular tip member 25 is sealed at its distal end 53.

[00052] In a particular embodiment of a biliary-type retrieval basket 20 illustrated in FIG. 1A, the tubular tip member 25 is releasable at a predetermined force from the distal ends 24 of the basket wires 21. Referring to FIG. 6B, the tubular tip member 25 may be manufactured from sterling silver. The overall length of the tubular tip member 25 is 0.123 inches and the diameter at the narrowest region 25a is 0.0510 to 0.0520 inches. The inside diameter of the lumen 27 is 0.0352 to 0.0358 inches. The length of the lumen 27 is about 0.086 inches. The distal ends 24 of the basket wires 21 are inserted 0.0545 to 0.688 inches into the lumen 27 of the tubular tip member 25. The diameter of the tubular tip member at the widest region 25b is .085 inches. The distal end 25c of the tubular tip member 25 has a spherico-conical shape to ease cannulation and reduce the risk of trauma to surrounding tissue. The radius of the distal end 25c of the tubular tip member 25 is .030 inches.

[00053] Referring again to FIG. 6A, in one embodiment of the tip joint 25 of the invention, the distal ends 24 of the basket wires 21 are gripped by the tubular member 25 because the tip member 25 is reduced in diameter, i.e. swaged, to cause the wire ends 24 to be compressed together. In other embodiments of the invention, the distal ends 24 of the wires 21 may be joined by adhesives, solder, welding, over-molding, or other means of binding, or by any combination of joining methods, with or without a tubular tip member 25. All of the embodiments of the

WO 02/053037

PCT/US02/00383

- 12 -

distal ends 24 of the wires 21 have in common the feature that the distal ends 24 are releasable when a predetermined force is applied to the tip joint 25 causing the tip joint 25 to become disengaged from the wires 21.

5 [00054] Referring to FIGS. 7A, 7B, 7C, and 7D, in order to overcome the problems caused when a component of a medical retrieval device 10 breaks during retrieval of a stone 50 in a body tract, the tip joint 25, according to the invention has an interface which is releasable. By releasing the tip joint 25, the distal ends 24 of the basket wires 21 are freed, i.e. no longer joined together. With the distal ends 24 of the basket wires 21 free, the distal end of the retrieval basket 20 is open, as shown in FIG. 7C. To illustrate this point more clearly, referring to FIG. 7A, the  
10 retrieval basket 20 with captured stone 50 is shown extended beyond the distal end 15 of the sheath 12 in its expanded configuration. The retrieval basket 20 has a releasable tubular member 25 according to the invention.

[00055] Referring now to FIG. 7B, as traction is applied to traction member 40, the basket wires 21 tend to collapse around the stone 50 as the retrieval basket 20 enters the sheath 12. As  
15 an increasing amount of traction is applied to the traction member 40, the basket wires 21 tighten around the stone 50.

[00056] Referring to FIG. 7C, to release the stone 50, an operator applies tension to traction member 40 by pulling on traction member 40 in the proximal direction indicated by the arrow *a*. As basket wires 21 enter the distal end 15 of the sheath 12, a load generated at the tip joint 25 of  
20 the retrieval basket 20 that is less than the load that would cause one or more basket wires 21 to fail or break, but sufficient to cause deformation of the tubular tip member 25. When the tubular tip member 25 deforms, it loosens the grip of the basket wires 21 thereby allowing the distal ends 24 of the basket wires 21 to slide out of the tubular member 25. In one embodiment, the load required to cause the retrieval basket 20 to fail at the tip joint 25 is in the range of about 20  
25 to 50 pounds at the basket tip. In a particular embodiment, the load required to cause the retrieval basket 20 to fail at the tip joint 25 is about 42 pounds.

[00057] Thus, as illustrated in FIG. 7C, the distal ends 24 of the basket wires 21, slide out of tubular member 25 as the retrieval basket 20 is withdrawn further into the sheath 12. The stone 50, illustrated in FIG. 7C, is released from the retrieval basket 20 through the basket distal end.  
30 Referring to FIG. 7D, the retrieval basket 20 is withdrawn further into sheath 12 until the distal ends 24 of the basket wires 21 are retained within the sheath 12. With the basket wires 21 retained by sheath 12, the medical retrieval device 10 can be safely withdrawn from the body

WO 02/053037

PCT/US02/00383

- 13 -

tract.

- [00058] To ensure safe release of the stone 50 in overload conditions during stone retrieval, the retrieval basket distal tip joint 25 fails at a load that is less than the load which would cause any other component in the device 10, such as the traction member 40, to fail. The distal tip joint 25 is strong enough to perform the task for which the device 10 is intended, i.e., stone retrieval or reducing the size of the stone. The design of the device 10 must take the variation in strength of each component and joint of the retrieval device 10 into consideration to ensure that the that the tip joint 25 will fail at a lower load than will any other component or joint of the device 10.
- 10 [00059] FIG. 8 illustrates distribution of forces acting on the distal end 24 of the basket wires 21 restrained by a tip joint such as the tubular tip member 25. Tension, indicated by arrow *a*, on basket wires 21 is resolved into a force component B, indicated by arrow *b* that is aligned with the long axis 26 of the tubular tip member 25 and a force component C indicated by arrow *c* that is at an angle nearly perpendicular to the long axis 26 of the tubular tip member 25. The force component indicated by arrow *b* that is aligned with the long axis 26 of tip member 25 is resisted by the retention force E indicated by arrow *e* generated by the tubular tip member 25 on the basket wires 21. If the force component B aligned with the long axis 26 of the tubular tip member 25 exceeds the available retention force E, the basket wires 21 will slide out of the tubular tip member 25 and release the stone 50.
- 20 [00060] Retention force E, indicated by arrow *e* in FIG. 8, is a result of friction between the basket wires 21 and the tubular tip member 25. The friction between the basket wires 21 and the tubular tip member 25 is influenced by the pressure exerted on the distal ends 24 of the wires 21 by the tubular tip member 25, the surface form of the interior of the tubular tip member 25, the exterior of the basket wires 21, the physical dimensions of the tubular tip member 25, and the distance the distal ends 24 of the basket wires 21 are inserted within the tubular tip member 25. The force component C indicated by arrow *c* that is at an angle nearly perpendicular to the long axis 26 of the tubular tip member 25, acts upon the tubular tip member 25 to reduce the pressure exerted upon the basket wires 21, which reduces the friction and resulting retention force E indicated by arrow *e* in FIG. 8. As the tension A increases, the tubular tip member 25 begins to deform and, as a result, retention force E reduces. If the combined components of the basket wire tension cause the retention force E to be exceeded by the aligned force B, and the total tensile load on the basket wires 21 is less than their failure load, the basket wires 21 will be
- 25
- 30

WO 02/053037

PCT/US02/00383

- 14 -

released from the tip joint 25.

[00061] The amount of force required to cause tubular tip member 25 to release may also be changed, for example, by varying the crimp length of the tip, varying the thickness of the wall of the tubular region of the tip comprising the crimp, or by scoring the distal ends 24 of the basket wires 21.

[00062] Although the description above describes the action of basket wire tension upon a tubular tip member 25, a similar effect can be produced with other methods of joining the basket wires 21 where the forces acting upon the tip joint 25 exceed the strength of the tip joint 25 without exceeding the strength of the basket wires 21. For example, if the basket wires 21 are joined by welding, the weld joint 25 can be designed to fail at a load that is less than the load required to cause the basket wires 21 to fail. Because welding typically causes a localized reduction in the strength of the welded material, such a tip joint 25 can be readily produced. Alternatively, the basket wires 21 may be joined by an adhesive or solder where the mechanical properties of the adhesive or solder material will allow failure of the tip joint 25 at a load that is lower than the failure load of basket wire 21. Alternatively yet, the basket wires 21 may be joined by forming a tip joint 25 around the distal ends 24 of the wires by molding or casting a meltable material such as metal or thermoplastic, or by molding a curable liquid, such as a thermosetting polymer or epoxy around the distal ends 24 of the basket wires 21. The joining method and materials used are dictated largely by the loading requirements of the medical device 10. For example, with respect to medical devices intended for simple stone retrieval without lithotripsy, the sheath 12 and retrieval basket 20 are constructed of lighter and more flexible materials to allow easier capture of the stone 50. Because the strength of components comprising such a device is low as compared to devices intended for lithotripsy, the basket wire 21 could be joined at the distal tip joint 25 by adhesive, which would allow release of the stone 50 at a more modest load.

[00063] FIG. 9 illustrates the design rationale of the medical retrieval device according to the invention including a retrieval basket 20 with a releasable tip joint 25. Curve A illustrates the distribution of basket tip joint 25 failure forces and curve B illustrates the distribution of the failure forces of all other components of the medical retrieval device 10. The distribution of failure forces for basket tip joint 25 is sufficiently lower than the distribution of failure forces for all other components of device 10. Thus, the probability that the basket tip joint 25 strength exceeds the strength of any other component of the device 10 is exceedingly small.

WO 02/053037

PCT/US02/00383

- 15 -

[00064] In another aspect of the invention, the medical device 10, including the retrieval basket 20 according to the invention, is used in a method for removing stones 50 from a body tract. The body tract may be any cavity in the body including but not limited to pancreatic ducts, biliary ducts including the hepatic ducts, cystic duct, and common bile duct, ureter, urethra, urinary bladder and kidney.

[00065] Referring again to FIGS. 1A-1C and 7A-7D, in this aspect of the invention, in general, an operator inserts the medical device 10 according to the invention including retrieval basket 20 into the working channel of an endoscope with the retrieval basket 20 in the closed position within sheath 12 as illustrated in FIG. 1A. The medical device 10 alternatively may be passed over a .035 inch guidewire, such as a Jagwire™ guidewire, manufactured by Boston Scientific Corporation of Natick, Massachusetts, using a sidecar 19, through the working channel of the endoscope. Once the device has accessed the body tract of interest, typically an injection of contrast material is made for fluoroscopic visualization. When the retrieval basket 20 approaches the stone or stones 50 to be captured and fragmented, the traction member 40 is advanced distally (in the direction away from the operator) advancing retrieval basket 20 into its expanded configuration where the retrieval basket 20 is no longer restrained by sheath 12. The retrieval basket 20 assumes its expanded configuration outside the distal end 15 of the sheath 12. Then, the operator maneuvers the expanded retrieval basket 20 around stone 50 until stone 50 passes between the basket wires 21 into the retrieval basket 20. Generally, after a stone 50 is captured in the retrieval basket 20, the medical retrieval device 10 including the retrieval basket 20 and captured stone 50 is withdrawn through the body tract. If the combination of the stone 50 and retrieval basket 20 is too large to be withdrawn from the body tract, the stone 50 must be reduced in size or released from the basket 20. To reduce the size of the stone 50 according to the invention, the stone 50 is fragmented by applying traction in the proximal direction to traction member 40 by actuating mechanism 32 forcing basket wires 21 to tighten around stone 50. The degree of force applied to traction member 40 is increased to generate sufficient tension within basket wires 21 to cause the stone 50 to fragment. If additional tension is required to facilitate lithotripsy, the handle 30 may be attached to an Alliance II™ Inflation System, manufactured by Boston Scientific Corporation of Natick, Massachusetts, or to a mechanical lithotripsy system by removing the handle 30 and the sheath 12, and attaching the traction member 40 to the handle of the lithotripsy system. Additional tension may be required when the actuating mechanism 32 in the handle 30 is unable to generate sufficient tension in the basket wires 21, where, for example, the retrieval basket 20 is in almost collapsed position when the

WO 02/053037

PCT/US02/00383

- 16 -

stone 50 is captured because of the small size of the stone 50.

[00066] According to the invention, when the tension needed to fragment the stone 50 approaches the force that would cause any component of the device 10 to fail, the tip joint 25 fails first. In some cases, however, the traction member 40 may fail at the distal end 17 of the handle 30, where, for example, a particular path of the catheter in the patient's body tract results in an increased friction at the proximal end 9 of the traction member 40. If the traction member 40 so fails, a mechanical lithotripsy system can be attached to the traction member 40 by removing the handle 30 and the sheath 12, and attaching the traction member 40 to the handle of the lithotripsy system to provide tension to the basket wires 21 to fragment the stone 50 or achieve the release of the tip joint 25 when the tension needed to fragment the stone 50 approaches the force that would cause any component of the medical device 10 to fail.

[00067] According to one embodiment of the invention, the tip joint 25 fails when the distal ends 24 of basket wires 21 are freed by releasing tubular tip member 25 as illustrated in FIGS. 7C-7D. As the operator applies traction in the proximal direction on the traction member 40, the tubular tip member 25 is released from the distal ends 24 of the basket wires 21 when the force applied to the basket wires 21 through the traction member 40 is less than the force required to cause the basket wires 21 to break, but great enough to cause tubular tip member 25 to deform thereby allowing basket wires 21 to slide out of tubular tip member 25. In one embodiment of the invention, the force required to cause tip member 25 to be released from the distal ends 24 of the basket wires 21 is in the range of about 20 to 50 pounds at the basket tip.

[00068] It will be apparent to those skilled in the art of medical stone retrieval that various modifications and variations can be made to the above-described structure and methodology without departing from the scope or spirit of the invention.

WO 02/053037

PCT/US02/00383

- 17 -

CLAIMS

- 1 1. A medical device for removing objects from a body, comprising:
  - 2 a basket comprising a plurality of wires, the wires comprising a proximal end and
  - 3 a distal end, and
  - 4 a tip joint disposed at the distal end of the basket wires, wherein the tip joint is
  - 5 releasable from the distal ends of the wires when a predetermined force is applied to
  - 6 the tip joint.
- 1 2. The device of claim 1 further comprising:
  - 2 a handle,
  - 3 a sheath extending distally from the handle, the sheath having a lumen extending
  - 4 therethrough from a distal end of the sheath to a proximal end of the sheath, and
  - 5 an elongate traction member axially disposed within the lumen of the sheath, the
  - 6 traction member distally extending from the handle and connected to the proximal end
  - 7 of the basket.
- 1 3. The device of claim 2 wherein the predetermined force is less than the force required to
- 2 cause the traction member or at least one wire of the basket to fail.
- 1 4. The device of claim 1 wherein the tip joint is selected from a group consisting of an
- 2 adhesive joint, a solder joint, a welded joint and an over-molding joint.
- 1 5. The device of claim 3 wherein the tip joint comprises a tubular tip member having a
- 2 distal end, a proximal end, and a lumen extending therethrough, wherein the lumen of the
- 3 tubular tip member is adapted to receive the distal end of the basket therein.
- 1 6. The device of claim 5 wherein the lumen of the tubular tip member is compressed around
- 2 the basket wires thereby securing the distal end of the basket therein.
- 1 7. The device of claim 5 wherein at least one wire of the plurality of wires forming the
- 2 basket is capable of sliding out of the tubular tip member when the predetermined force is
- 3 applied to the tip joint.
- 1 8. The device of claim 5 wherein the tubular tip member deforms at a force that is less than
- 2 the force required to cause the traction member or at least one wire of the plurality of
- 3 wires forming the basket to fail.
- 1 9. The device of claim 8 wherein the tubular tip member is manufactured from a material
- 2 which deforms at a force that is less than the force required to cause the traction member
- 3 or at least one wire of the plurality of wires forming the basket to fail.
- 1 10. The device of claim 8 wherein the tubular tip member is manufactured from a material

WO 02/053037

PCT/US02/00383

- 18 -

- 2 selected from a group consisting of silver-based alloy, silver, gold, platinum, stainless  
3 steel, and nickel titanium alloy.
- 1 11. The device of claim 8 wherein the tubular tip member is manufactured from sterling  
2 silver.
- 1 12. The device of claim 8 wherein the tubular tip member is manufactured from plastics.
- 1 13. The device of claim 8 wherein the force that is less than the force required to cause the  
2 traction member or at least one wire of the plurality of wires forming the basket to fail is  
3 in the range of about 20 pounds to 50 pounds.
- 1 14. The device of claim 2 wherein the traction member is selected from a group consisting of  
2 a cable, a coil, a shaft, a guidewire and a mandril wire.
- 1 15. The device of claim 2 wherein the traction member and the basket are formed from a  
2 single piece of material.
- 1 16. The device of claim 2 wherein the basket wires are joined to the traction member by a  
2 proximal connector.
- 1 17. The device of claim 16 wherein the proximal connector is selected from a group  
2 consisting of an adhesive joint, a solder joint, a welded joint and an over-molding joint.
- 1 18. The device of claim 16 wherein the proximal connector comprises a proximal tubular  
2 member having a distal end, a proximal end, and a lumen extending therethrough,  
3 wherein the lumen of the proximal tubular member is adapted to receive the proximal end  
4 of the basket therein.
- 1 19. The device of claim 18 wherein the lumen of the proximal tubular member is compressed  
2 around the basket wires thereby securing the proximal end of the basket therein.
- 1 20. The device of claim 19 wherein the proximal tubular member is manufactured from  
2 stainless steel.
- 1 21. The device of claim 2 wherein the basket is moveable between a withdrawn position in  
2 which the basket is collapsed within the lumen of the sheath, and an expanded position in  
3 which the basket extends from the distal end of the sheath and is disposed outside of the  
4 lumen for capturing the objects in the body.
- 1 22. The device of claim 21 wherein movement of the basket between the expanded position  
2 and the withdrawn position causes the objects in the body to fragment.
- 1 23. The device of claim 2 wherein the handle comprises at least one actuating mechanism  
2 therein.
- 1 24. The device of claim 2 wherein the traction member is slideably moveable relative to the

WO 02/053037

PCT/US02/00383

- 19 -

- 2 sheath.
- 1 25. The device of claim 2 wherein the traction member is connected to the actuating  
2 mechanism, the actuating mechanism causing the traction member to shift the basket  
3 between the withdrawn position and the expanded position.
- 1 26. The device of claim 2, wherein the sheath is slideably moveable relative to the traction  
2 member.
- 1 27. The device of claim 2 wherein the sheath is connected to the actuating mechanism at the  
2 handle, the actuating mechanism causing the sheath to shift the basket between the  
3 withdrawn position and the expanded position.
- 1 28. The device of claim 1 wherein the plurality of wires comprise stainless steel.
- 1 29. The device of claim 1 wherein the plurality of wires comprise a nickel titanium alloy.
- 1 30. The device of claim 3 wherein the handle is detachable.
- 1 31. The device of claim 3, wherein the sheath is dimensioned to fit within a working channel  
2 of an endoscope.
- 1 32. A method for removing objects from a body tract, comprising the steps of:  
2 providing a medical device comprising:  
3 a handle,  
4 a sheath extending distally from the handle, the sheath having a lumen  
5 extending therethrough from a distal end of the sheath to a proximal end of  
6 the sheath, the sheath is dimensioned to fit within a working channel of an  
7 endoscope,  
8 a basket comprising a plurality of wires, the wires comprising a proximal end  
9 and a distal end, the basket moveable between a withdrawn position in  
10 which the basket is collapsed within the lumen of the sheath, and an  
11 expanded position in which the basket extends from the distal end of the  
12 sheath and is disposed outside of the lumen for capturing the objects in the  
13 body, and  
14 a tip joint disposed at the distal end of the basket wires, wherein the tip joint is  
15 releasable from the distal ends of the wires when a predetermined force is  
16 applied to the tip joint;  
17 introducing the medical device with the basket in the withdrawn position into the  
18 working channel of the endoscope;  
19 accessing the target body tract;

WO 02/053037

PCT/US02/00383

- 20 -

- 20 shifting the basket into the expanded position;  
21 manipulating the basket to capture the objects therein; and  
22 withdrawing the medical device from the body tract.
- 1 33. The method of claim 32, wherein the medical device further comprises an elongate  
2 traction member axially disposed within the lumen of the sheath.
- 1 34. The method of claim 32, wherein the predetermined force is less than the force required  
2 to cause the traction member or at least one wire of the basket to fail.
- 1 35. The method of claim 32, further comprising the step of applying traction to the traction  
2 member in the proximal direction thereby generating tension within the basket and  
3 causing the captured objects to fragment.
- 1 36. The method of claim 32, further comprising the step of applying traction to the sheath in  
2 the distal direction thereby generating tension within the basket and causing the captured  
3 objects to fragment.
- 1 37. The method of claim 32, further comprising the step of injecting contrast material for  
2 fluoroscopic visualization.

WO 02/053037

PCT/US02/00383

1/15

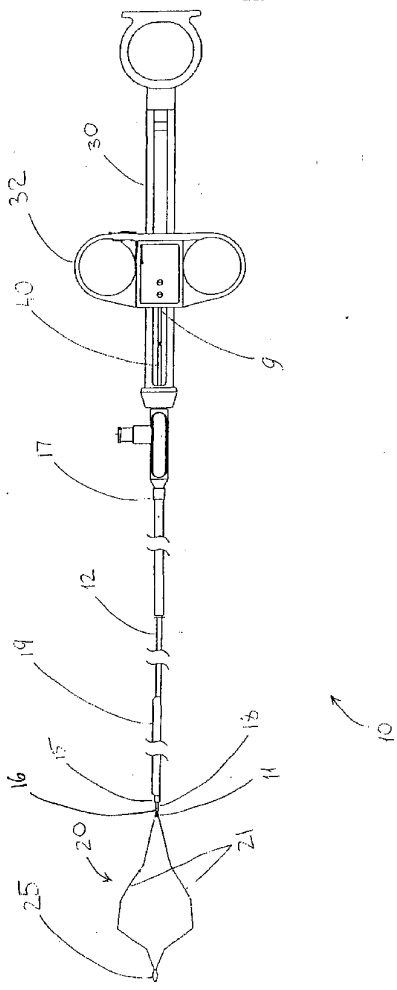

FIG. 1A

WO 02/053037

PCT/US02/00383

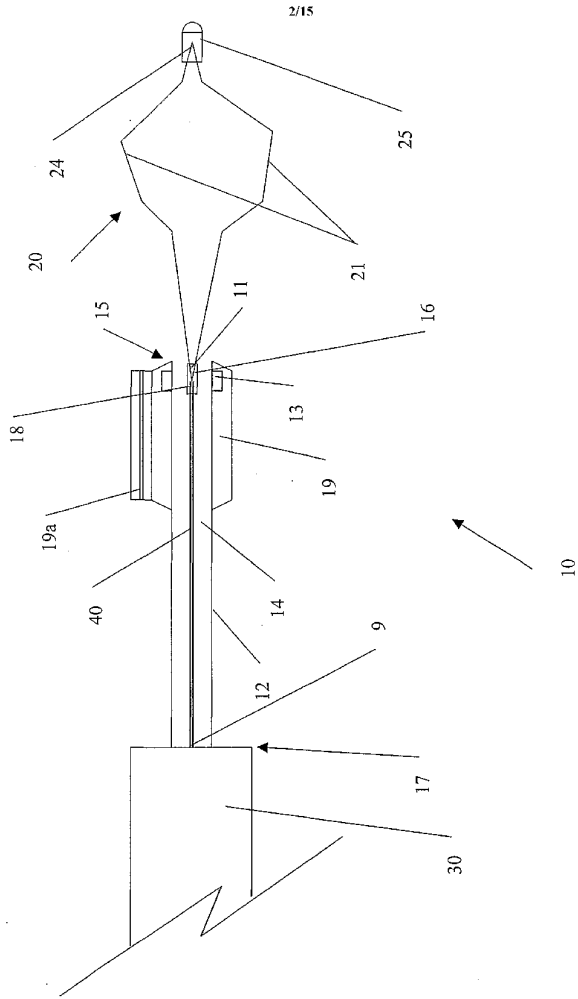

FIG. 1B

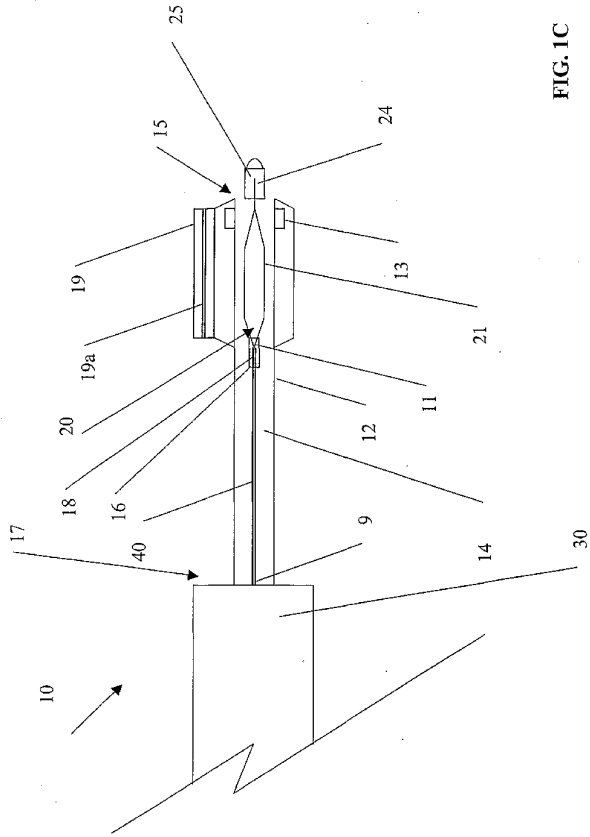

FIG. 1C

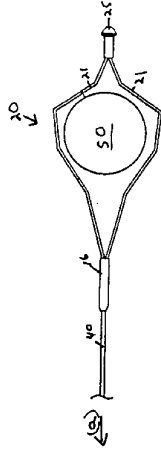

FIG. 2

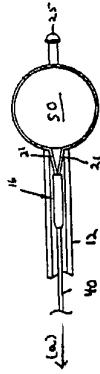

FIG. 3



WO 02/053037

7/15

PCT/US02/00383

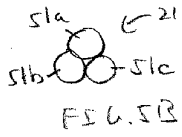
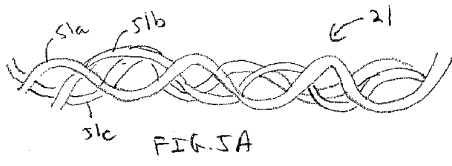

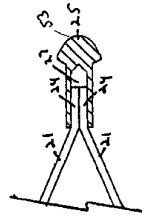

FIG. 6A

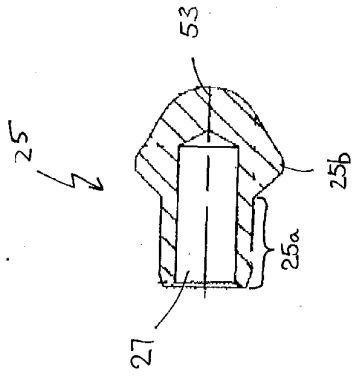
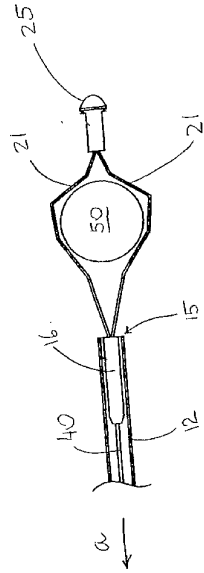

FIG. 6B

FIG. 7A



WO 02/053037

11/15

PCT/US02/00383

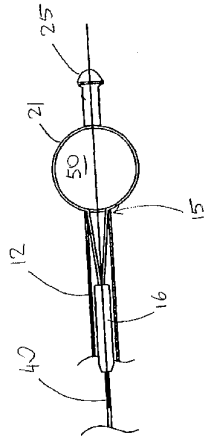

FIG. 7B

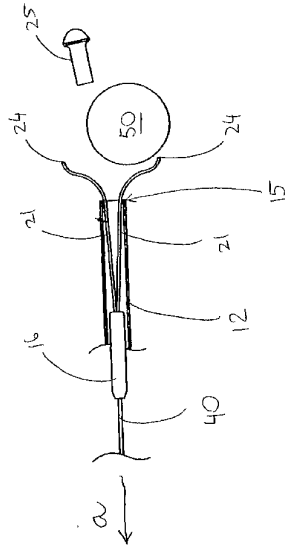

FIG. 7C

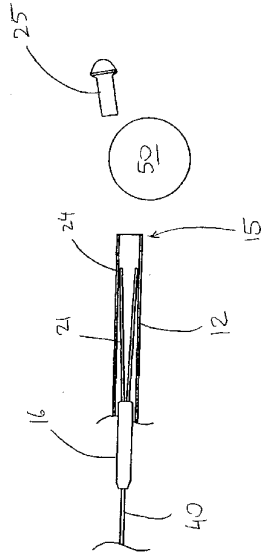

FIG. 7D

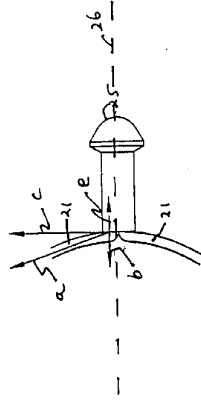

FIG. 8

WO 02/053037

PCT/US02/00383

15/15

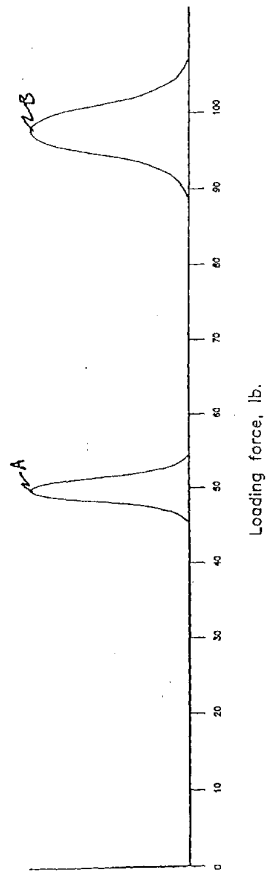

FIG. 9

## 【国際公開パンフレット(コレクトバージョン)】

(12) INTERNATIONAL APPLICATION PUBLISHED UNDER THE PATENT COOPERATION TREATY (PCT)

CORRECTED VERSION

(19) World Intellectual Property Organization  
International Bureau(43) International Publication Date  
11 July 2002 (11.07.2002)

PCT

(10) International Publication Number  
WO 02/053037 A2

- (51) International Patent Classification: A61B 17/00  
CZ, DE, DK, DM, DZ, EC, EE, ES, FI, GB, GD, GE, GH, GM, IIR, IU, ID, IL, IN, IS, JP, KE, KG, KP, KR, KZ, LC, LK, LR, LS, LT, LU, LV, MA, MD, MG, MK, MN, MW, MX, MZ, NO, NZ, OM, PH, PL, PT, RO, RU, SD, SE, SG, SI, SK, SL, TJ, TM, TN, TR, TT, TZ, UA, UG, UZ, VN, YU, ZA, ZW.
- (21) International Application Number: PCT/US02/00383
- (22) International Filing Date: 7 January 2002 (07.01.2002)
- (25) Filing Language: English
- (26) Publication Language: English
- (30) Priority Data: 60/260,299 8 January 2001 (08.01.2001) US
- (71) Applicant: SCIMED LIFE SYSTEMS, INC. [US/US]; One Scimed Place, Maple Grove, MN 55311-1566 (US).  
Published: without international search report and to be republished upon receipt of that report
- (72) Inventors: REYNOLDS, Robert; 9 Buckhill Road, Northboro, MA 01532 (US). RICHARDSON, M. Kevin; 19 Breakneck Hill Road, Hopkinton, MA 01748 (US). BOWEN, Mark; 13 Red Acre Road, Stow, MA 01775 (US).  
(48) Date of publication of this corrected version: 31 October 2002
- (74) Agent: BELOBORODOV, Mark, L.; Testa, Hurwitz & Thibault, T.J.P. High Street Tower, 125 High Street, Boston, MA 02110 (US).  
(15) Information about Correction: see PCT Gazette No. 44/2002 of 31 October 2002, Section II
- (81) Designated States (national): AE, AG, AL, AM, AT, AU, AZ, BA, BB, BG, BR, BY, BZ, CA, CH, CN, CO, CR, CU, CZ, DE, DK, DM, DZ, EC, EE, ES, FI, GB, GD, GE, GH, GM, IIR, IU, ID, IL, IN, IS, JP, KE, KG, KP, KR, KZ, LC, LK, LR, LS, LT, LU, LV, MA, MD, MG, MK, MN, MW, MX, MZ, NO, NZ, OM, PH, PL, PT, RO, RU, SD, SE, SG, SI, SK, SL, TJ, TM, TN, TR, TT, TZ, UA, UG, UZ, VN, YU, ZA, ZW.
- For two-letter codes and other abbreviations, refer to the "Guidance Notes on Codes and Abbreviations" appearing at the beginning of each regular issue of the PCT Gazette.*

WO 02/053037 A2

(54) Title: RETRIEVAL BASKET WITH RELEASABLE TIP

(57) Abstract: A medical retriever device is used to retrieve and/or fragment stones (and/or other objects) from the body of a patient. The device has a retrieval basket with a releasable tip. The tip release is designed to release in a controlled pre-determined manner and under a pre-determined force before any other component of the device fails due to a force exerted on the basket.

WO 02/053037

PCT/US02/00383

**RETRIEVAL BASKET WITH RELEASABLE TIP****TECHNICAL FIELD**

[0001] The present invention generally relates to medical retrieval devices for capturing material such as stones within a body and to medical retrieval devices featuring a basket which captures one or more stones located in a body tract and which optionally fragments, crushes, or releases the stones.

**BACKGROUND OF THE INVENTION**

[0002] Medical retrieval devices for capturing stones in a body tract generally include a basket. Some medical retrieval baskets are also mechanical lithotriptors which optionally crush or fragment stones that are too large to be removed intact from the body tract after the stone has been captured within the basket. One type of known device for crushing or breaking stones in a body tract has a wire basket that is typically introduced into a body tract via a working channel of an endoscope or by means of a guidewire.

[0003] Baskets designed for mechanical retrieval are typically constructed from a plurality of wires that are arranged and shaped such that their natural form, when unrestrained, is to expand radially outward. The basket wires are gathered together at their distal ends and at their proximal ends to form a basket. An elongated traction member typically extends from the basket through a sheath to a handle.

[0004] A typical retrieval basket is introduced into a body tract via an endoscope or catheter and maneuvered around the stone until the stone enters the basket. If it is necessary to reduce the size of the stone, it is then fragmented typically by applying tension to the basket wires surrounding the stone until sufficient force is applied directly to the stones by the basket wires to cause the stone to break apart.

[0005] Mechanical limitations and wide variation in the size, location, shape, and composition of stones in the body present problems in retrieving stones in a body tract. Methods that are used to reduce the size of the stone include lithotripsy such as by acoustic shock waves delivered to the stone from within or outside the body, laser energy applied directly to the stone, or compressive force applied to the stone by means of a mechanical basket. If mechanical basket

WO 02/053037

PCT/US02/00383

- 2 -

lithotripsy is attempted on a stone composed of very hard material, the basket wire tension required to fragment the stone may exceed the strength of the basket wires, the various connecting joints of the medical device, the elongated traction member attached to the basket base, or the sheath. If the path of the body tract is very tortuous, the bends in the body tract will cause intimate contact of the traction member with the interior surface of the sheath. The friction generated between the traction member and the sheath will cause the tension applied to the proximal end of the traction member to be greatly reduced when delivered to the basket wires. It is possible for the mechanical strength of the basket wires, the various connecting joints in the device, the traction member, or the sheath to be exceeded even when fragmenting stones of only moderately hard composition.

[0006] Failure of the medical retrieval device, including the retrieval basket or any of its components, following capture of a stone may require release of the stone before the basket can be withdrawn from the body tract. Failure of a medical device may occur, for example, near the proximal end of a traction member impairing the ability of the operator to manipulate the basket from the proximal end of the device to remove the basket and captured stone from the body tract. Alternatively, the traction member may fail at the distal end of the device. The broken end of the traction member may traumatize the lining of the body tract if an attempt is made to withdraw the failed device from the body tract. If one or more of the basket wires fail, it may be impossible to remove the basket via the same route by which the basket was introduced into the body tract without traumatizing the lining of the body tract with the fragmented ends of the broken basket wires.

[0007] With most known retrieval baskets, it is difficult to disengage the stone from the basket so that the basket can be removed from the body tract. Retrieval baskets typically lack sufficient strength to break the stone. Attempts to perform lithotripsy may result in failure of the device, including failure of the retrievable basket or any of its components. If the stone can not be released from the basket, more invasive surgical approaches are required to disengage the stone from the basket and to remove the basket and stone from the body tract.

#### SUMMARY OF THE INVENTION

[0008] It is an object of the invention to provide a medical device useful for retrieval of one or more stones and/or other calculi, objects, or other material from a body tract of a patient, such as biliary and pancreatic ducts, hepatic ducts, cystic duct, common bile duct, ureters, urinary bladder, urethra, and kidney.

WO 02/053037

PCT/US02/00383

- 3 -

- [0009] Further, it is an object of the invention to provide a medical device capable of fragmenting a stone or other object in a body tract of a patient prior to removal. Finally, it is an object of the invention to provide a medical device capable of safe disengagement from the object being retrieved or fragmented and subsequent safe withdrawal of the device in case of failure of any of the components thereof during the procedure.
- 5 [00010] Accordingly, a medical device having a multi-wire retrieval basket which is releasable when an amount of force that is less than the amount of force required to cause failure of components of the retrieval device other than the tip joint is applied to the wires of the basket is disclosed herein.
- 10 [00011] In general, in one aspect, the invention features a medical device comprising a handle, a sheath, and a basket. The sheath, having a lumen formed therein, distally extends from the handle. In one embodiment of the invention, the basket consists of a plurality of wires having a proximal end and a distal end. The proximal ends of the basket wires are joined at a basket base and the distal ends of the basket wires are releasably joined by a tip joint. An elongate
- 15 traction member may be axially disposed within the lumen of the sheath. In one embodiment, the traction member distally extends from the proximal end of the handle and is connected to the basket base. The traction member may comprise a cable, a coil, a shaft, a guidewire or a mandril wire. In one embodiment, the traction member and the basket wires may be formed from a single piece of material. In another embodiment, the proximal ends of the basket wires are
- 20 joined at the basket base to the traction member by a proximal connector.
- [00012] The tip joint is releasable from the distal end of the basket wires when the predetermined force, which is less than the force required to cause the traction member or at least one basket wire to fail, is applied to the tip joint.
- [00013] Embodiments of this aspect of the invention include the following features. The tip
- 25 joint may comprise an adhesive joint, a solder joint, a welded joint or an over-molding joint. In one embodiment, the tip joint comprises a tubular tip member. The lumen of the tubular tip member is adapted to receive the distal end of the basket therein. In a particular embodiment, the lumen of the tubular tip member is compressed around the basket wires thereby securing the distal end of the basket therein. At least one wire of the plurality of wires forming the basket is
- 30 capable of sliding out of the tubular tip member when the predetermined force is applied to the tubular tip member so that the tubular tip member deforms. The predetermined force is less than the force required to cause the traction member or at least one wire of the plurality of wires

WO 02/053037

PCT/US02/00383

- 4 -

forming the basket to fail. In one embodiment, the tubular tip member is made of, for example, sterling silver, silver, gold, platinum, stainless steel, or a nickel titanium alloy. In other embodiments, the tubular tip member is made of plastics.

5 [00014] In one embodiment of the invention, the basket is moveable between a withdrawn position in which the basket is collapsed within the lumen of the sheath, and an expanded position in which the basket extends from the distal end of the sheath and is disposed outside of the lumen for capturing the objects in the body. Movement of the basket between the expanded position and the withdrawn position causes the objects in the body captured in the basket to fragment.

10 [00015] In one embodiment of the invention, the handle includes at least one actuating mechanism. In a particular embodiment, the traction member is slideably moveable relative to the sheath when actuated by the actuating mechanism in the handle, which causes the traction member to shift the basket between the withdrawn position and the expanded position.

15 [00016] In another embodiment of the invention, the sheath is slideably moveable relative to the traction member. In this embodiment, the sheath is connected to the actuating mechanism at the handle, which causes the sheath to shift the basket between the withdrawn position and the expanded position.

[00017] The handle of the device according to the invention may be detachable. In one embodiment, the sheath is dimensioned to fit within a working channel of an endoscope. In one 20 embodiment, the plurality of wires forming the basket is made of, for example, stainless steel or a nickel titanium alloy.

[00018] In general, in another aspect, the invention features a method for removing objects from a body tract, including the steps of providing a medical device as described above, introducing the medical device with the basket in the withdrawn position into the working 25 channel of the endoscope; accessing the target body tract; shifting the basket into the expanded position; manipulating the basket to capture the objects therein; and withdrawing the medical device from the body tract. In a particular embodiment of this aspect of the invention, the method further includes the step of applying traction to the traction member in the proximal direction thereby generating tension within the basket and causing the captured objects to 30 fragment. In another embodiment, the method further includes the step of applying traction to the sheath in the distal direction thereby generating tension within the basket and causing the

WO 02/053037

PCT/US02/00383

- 5 -

captured objects to fragment. In some embodiments, the method also includes the step of injecting contrast material for fluoroscopic visualization.

## BRIEF DESCRIPTION OF THE DRAWINGS

- 5 [00019] In the drawings like reference characters generally refer to the same parts throughout the different views. The drawings are not necessarily to scale, emphasis instead generally being placed upon illustrating the principles of the invention.
- [00020] FIG. 1A illustrates an embodiment of a medical retrieval device according to the invention with the basket in the expanded position.
- 10 [00021] FIG. 1B illustrates an enlarged cross-sectional view of the basket and the sheath according to the embodiment of the invention illustrated in FIG. 1A with the basket in the expanded position.
- [00022] FIG. 1C illustrates an enlarged cross-sectional view of the basket and the sheath according to the embodiment of the invention illustrated in FIG. 1A with the basket in the withdrawn position.
- 15 [00023] FIG. 2 illustrates a basket with a captured stone, the basket extended from the sheath.
- [00024] FIG. 3 illustrates a basket with a captured stone, the basket partially withdrawn into the distal end of the sheath.
- [00025] FIG. 4 illustrates an embodiment of a retrieval basket according to the invention.
- [00026] FIG. 5A illustrates an enlarged view of the structure of the basket wire according to one embodiment of the invention.
- 20 [00027] FIG. 5B illustrates a sectional view of the basket wire according to the embodiment of the invention shown in FIG. 5A.
- [00028] FIG. 6A illustrates an embodiment of the tip joint of the retrieval basket according to the embodiment of the invention.
- 25 [00029] FIG. 6B illustrates an enlarged cross-sectional view of the tip joint of the retrieval basket according to the embodiment invention shown in FIG. 6A.
- [00030] FIG. 7A illustrates a step in releasing a captured stone from the retrieval device according to the invention.
- [00031] FIG. 7B illustrates another step in releasing a captured stone from the retrieval device

WO 02/053037

PCT/US02/00383

- 6 -

according to the invention.

[00032] FIG. 7C illustrates another step in releasing a captured stone from the retrieval device according to the invention.

5 [00033] FIG. 7D illustrates another step in releasing a captured stone from the retrieval device according to the invention.

[00034] FIG. 8 illustrates the forces acting on the tip joint of the retrieval basket according to the invention.

[00035] FIG. 9 graphically illustrates failure load for the tip joint compared to failure load for all other components of the retrieval device according to the invention.

10 DESCRIPTION

[00036] All of the following disclosed embodiments of the medical retrieval device according to the invention generally have at least one thing in common, and that is that the tip of a multi-wire retrieval basket is releasable when an amount of tensile force that is less than the amount of force required to cause failure of components of the retrieval device other than the tip joint, for example, the traction member, is applied to the wires of the basket. Failure of one or more components of the retrieval device means that the component is no longer useful for its intended purpose, because of, for example, permanent deformation or breakage. The retrieval basket of the invention is used to retrieve one or more stones and/or other calculi, objects, or other material from a body tract such as biliary and pancreatic ducts, hepatic ducts, cystic duct, common bile duct, ureters, urinary bladder, urethra, and kidney.

20 [00037] Referring to FIGS. 1A-1C, the medical device 10, according to the invention, includes a handle 30, a catheter, such as a sheath 12, and a retrieval basket 20 slideably moveable in the sheath 12. Alternatively, the retrieval basket 20 can be fixed in a stationary position with the sheath 12 configured to be slideably moveable to expose (FIG. 1A-1B) and cover/collapse (FIG. 1C) the basket 20. The retrieval basket 20 is flexibly connected to one or more elongated traction members 40 by a proximal connector 16. Alternatively, the retrieval basket and one or more traction members 40 can be made from a single piece of material. The retrieval basket 20 is of a type that can be collapsed within a sheath 12 for entry into the body. In general, the handle 30, sheath 12, and retrieval basket 20 illustrated in FIGS. 1A-1C are not necessarily shown in their correct size or proportion to each other. In one embodiment, the handle 30 is detachable from the rest of device 10 without disassembly of the entire device 10,

WO 02/053037

PCT/US02/00383

- 7 -

and a new handle 30 may be attached. In one embodiment, the handle and catheter assembly must be compatible with and attachable to a handle system, such as Alliance II™ Inflation System, manufactured by Boston Scientific Corporation of Natick, Massachusetts, without disassembly. In another embodiment, the basket and the traction member must be compatible with and attachable to a mechanical lithotripsy system by removing the handle 30 and the sheath 12, and attaching the traction member 40 to the handle of the lithotripsy system.

[00038] The size of the entire sheath 12 is dimensioned to fit the requirements of the application of the sheath 12 in the body. For example, for most biliary type applications, the working length of the device 10 from the distal end 15 of the sheath 12 to the distal end 17 of the handle 30 ranges from about 60 inches (150 cm) to about 120 inches (300 cm), preferably about 70.9 inches (180+/- 0.5 cm). In one embodiment, the size of the basket 20 and sheath 12 is dimensioned to fit in a 3.2 mm diameter or larger working channel of an endoscope, such as duodenoscope.

[00039] Referring to FIGS. 1B-1C, the sheath 12 has at least one lumen 14 therein that extends from the handle 30 to the distal end of the sheath 15. In one embodiment of the invention, the sheath 12 includes a wire coil reinforced tube terminated distally by a reinforcement ring, such as a stainless steel reinforcement ring 13 illustrated in FIGS. 1B and 1C. In a particular embodiment of the invention, the reinforcement ring is made of 303 stainless steel. The wire coil is made of stainless steel, for example, 304 stainless steel, and is coated with polytetrafluoroethylene (PTFE) to provide a low friction surface. As one of ordinary skill would appreciate, the 300 series stainless steels are nickel-chromium austenitic steels with low carbon content. Particularly, 303 stainless steel typically contains 17-19% chromium, 8-10% nickel, .15-.45% sulfur, no more than .15% carbon, no more than 2% manganese, no more than .02% phosphorus, no more than .6% molybdenum, and no more than 1% Si with balance iron. Further, 304 stainless steel typically contains 18-20% chromium, 8-10.5% nickel, no more than .03% sulfur, no more than .08% carbon, no more than 2% manganese, no more than .45% phosphorus, and no more than 1% Si with balance iron.

[00040] The device 10 can be used in conjunction with a guidewire, such as, for example, a .035 Jagwire™ guidewire available from Boston Scientific Corporation of Natick, Massachusetts. In such embodiment, the sheath 12 also includes a sidecar 19 located at the distal end 15 of the sheath 12 extending proximally therefrom. The sidecar 19 has a lumen 19a therein adapted to receive a guidewire. The lumen 19a may be lined with polytetrafluoroethylene

WO 02/053037

PCT/US02/00383

- 8 -

(PTFE), perfluoroethylenepropylene (FEP), or similar coating. The ends of the sidecar 19 are tapered to promote cannulation and withdrawal and to avoid inflicting trauma to surrounding tissues. In a particular embodiment of the invention, the diameter of the lumen 19a of the sidecar 19 is in the range of about .035 inches to .040 inches, preferably 0.038 inches; and the length of the sidecar is in the range of about 7 inches to about 10 inches, preferably 8.25 inches.

5 [00041] An elongated traction member 40 can be a cable, coil, shaft, guidewire or mandril wire 40 and extends within the lumen 14 of the sheath 12 from the handle 30. In a particular embodiment, the traction member 40 is a 304 stainless steel wire. In one embodiment, the traction member 40 is joined at its proximal end 9 to at least one actuating mechanism 32 at the device handle 30 and at its distal end 18 to the base 11 of the retrieval basket 20. In another 10 embodiment, the traction member 40 is joined at its proximal end 9 to handle 30, and at its distal end 18 to the base 11 of the retrieval basket 20. In yet another embodiment, the traction member 40 and the basket wires 21 are formed from a single piece of material.

[00042] Referring to FIGS. 1B and 1C, operation of one or more actuating mechanisms 32 on the handle 30 by an operator causes the traction member 40 to slideably move in the sheath 12 15 causing the retrieval basket 20 to move in and out of the sheath 12. Alternatively, the mechanism 32 can cause movement of the sheath 12 to advance the sheath 12 over the stationary retrieval basket 20 and traction member 40 combination to thereby collapse the retrieval basket 20 within the sheath 12, and the mechanism 32 can slide the moveable sheath 12 back to expose 20 the stationary retrieval basket 20 and allow it to open/expand. In general, both types of retrieval basket /sheath movement configurations and related handle mechanisms are known, and can be seen in existing product designs available from, for example, Boston Scientific Corporation of Natick, Massachusetts.

[00043] With the retrieval basket 20 collapsed within the sheath 12 as shown in FIG. 1C, the sheath 12 can be inserted into the body by an operator to a site in the body where the stone 50 or stones to be retrieved are located (e.g., a stone in the common bile duct). By placing the retrieval basket 20 into its expanded position, as illustrated in FIGS. 1A, 1B, and 2, the retrieval basket 20 can be manipulated by the operator to entrap or capture a stone 50 within the retrieval basket 20. 25 In some clinical situations it is desirable to fragment the captured stone(s) 50. For example, when the combination of the stone 50 and basket 20 is too large to be withdrawn atraumatically 30 from the body tract, the stone 50 may be fragmented by, for example, mechanical lithotripsy.

[00044] Referring now to FIGS. 2 and 3, according to the invention, stone 50 is fragmented

WO 02/053037

PCT/US02/00383

- 9 -

by applying traction on the traction member 40 in a proximal direction indicated by arrow *a* in FIG. 2. Referring now to FIG. 3, as traction is applied to traction member 40, the basket wires 21 tend to collapse around the stone 50 as the retrieval basket 20 enters the sheath 12. As an increasing amount of traction is applied to the traction member 40, the basket wires 21 tighten around the stone 50 until the tension generated in the wires 21 is sufficient to crush or fragment the stone 50.

[00045] Referring to FIG. 4, in one embodiment, the retrieval basket 20 is composed of a plurality of wires 21, such as four wires 21a, 21b, 21c, 21d spaced at 90 degree angle apart from each other that are bent or formed to provide the desired basket shape. The basket wires 21 in one embodiment are round, or alternatively, rectangular in cross section. Other cross-sectional wire shapes are also contemplated by the invention, such as D-shaped or V-shaped. In one embodiment, each of wires 21 is formed with four bends so that the width of the basket 20 in its expanded position is greater at the distal end 24 of the wires 21 than at the proximal end 11 of the retrieval basket 20 to ease effective capture of stones 50. The basket wires 21 may be manufactured from stainless steel, nickel titanium, other metal alloys, or other materials or combinations of materials known in the art suitable for basket wires. In a particular embodiment of the invention, the basket wires are manufactured from a nickel-titanium alloy containing between 54% and 57.5% nickel with balance titanium. In one embodiment of the invention, the radial stiffness of the basket wires 21 is greater than .7 g/mm. In another embodiment of the invention the radial stiffness of the basket wires 21 is greater than 1.0 g/mm.

[00046] Other numbers of basket wires and other wire shapes are also contemplated by the invention other than the four bent wires illustrated in FIG. 4. The typical dimensions for a retrieval basket 20 for biliary applications, according to the invention, range from about 0.6 inches (1.5 cm) in diameter by about 1.8 inches (3 cm) in length to about 1.8 inches (3 cm) in diameter by about 2.36 inches (6.0 cm) in length. Preferably, the basket dimensions in one embodiment are about 0.6 inches (1.5 cm) in diameter by about 1.18 inches (3.0 cm) in length, in another embodiment, about 0.79 inches (2.0 cm) in diameter by about 1.58 inches (4.0cm) in length, in another embodiment, about 1.0 inch (2.5 cm) in diameter by about 1.97 inches (5.0 cm) in length, and in yet another embodiment, 1.18 inches (3.0 cm) in diameter by about 2.36 inches (6.0 cm) in length. The dimensions of the retrieval basket 20 may be smaller or larger depending on the application of the retrieval basket 20 in the body. For example, the dimensions of the retrieval basket 20 used for typical urinary tract applications may be smaller than the

WO 02/053037

PCT/US02/00383

- 10 -

basket used for biliary applications.

[00047] In one embodiment, illustrated in FIGS. 5A and 5B, for example, each of the basket wires 21 are manufactured from three filaments 51a, 51b, and 51c of 0.0085 inch PRECURSOR nickel titanium alloy twisted together into a single stranded cable 21.

- 5 [00048] The stones 50 that may be fragmented by the retrieval basket 20 according to the invention may vary in size from about 0.2 inches (0.5 cm) in diameter up to about 1.18 inches (3.0 cm) in diameter and vary in physical characteristics as soft, such as cholesterol stones 50, to hard, such as bilirubin stones 50. In one embodiment of the invention, the retrieval basket 20 is a four-wire basket capable of capturing up to five separate stones 50 for simple extraction without  
10 fragmenting the stones 50. In one embodiment, the retrieval basket 20 is capable of capturing up to five separate stones 50 for simple extraction without fragmenting the stones 50 where the force applied to the retrieval basket 20 does not exceed 20 pounds. In another embodiment, the retrieval basket 20 is capable of capturing up to five separate stones 50 for simple extraction without fragmenting the stones 50 where the force applied to the handle during each stone  
15 capture is a minimum of 15 pounds.

- [00049] In one embodiment, the retrieval basket 20 is capable of fragmenting at least two separate stones 50 where the force applied to the handle during each capture does not exceed the range of 25-50 pounds. In a particular embodiment, the retrieval basket 20 is capable of  
20 fragmenting at least two stones at a force that does not exceed 35 pounds for either stone. In another embodiment, the retrieval basket 20 is capable of fragmenting at least two separate stones 50 where the force applied to the handle during fragmenting of a first stone is at least 36 pounds, and the force applied to the handle during fragmenting of a second stone is at least 25 pounds. Following fragmentation of one or more stones 50, the retrieval basket 20 is fully capable of being fully collapsed in the lumen 14 of the sheath 12.

- 25 [00050] Referring again to FIG. 4, in one embodiment of the invention, the basket wires 21a, 21b, 21c, 21d of the retrieval basket 20 are joined at their proximal ends at the base 11 of the retrieval basket 20 by, for example, a proximal connector 16. In one embodiment, the proximal connector 16 comprises a tube having a lumen extending longitudinally therethrough. The proximal connector 16 is swaged to hold the wires 21a, 21b, 21c, 21d together tightly. Other  
30 methods of joining the wires 21a, 21b, 21c, 21d known in the art such as adhesives, solder, welding, or binding, or by any of their combination with or without proximal connector 16 may be used to join or gather together the proximal ends 52 of basket wires 21 at the basket base 11.

WO 02/053037

PCT/US02/00383

- 11 -

In one embodiment of the invention, the proximal connector 16 is made of 303 stainless steel and is joined to a 304 stainless steel traction member 40.

[00051] Referring now to FIG. 6A, according to the invention, the distal ends 24 of the basket wires 21 are gathered together and held in place by a tip joint 25. In one embodiment of the invention, tip joint 25 is a tubular tip member, for example, as illustrated in FIG. 6A and 6B. The tubular tip member 25 comprises a tube having a lumen 27 extending longitudinally through the tube. The tubular tip member 25 may be manufactured from materials such as sterling silver, coin silver or other silver-based alloys, pure silver, gold, platinum, stainless steel, nickel titanium, other metal alloys, or plastics. The material for the tubular tip member is chosen to fit the requirements of the application of the retrieval basket in the body. For example, if the tubular tip member 25 is manufactured from a silver-based alloy, for example silver/copper alloy, a higher percentage of silver would result in a softer alloy. As a result, the tubular tip member 25 will release from the basket wires 21 at a release force that is lower than that of the tubular tip member of identical dimensions made from an alloy with a lower percentage of silver. In one embodiment, the tubular tip member 25 is sealed at its distal end 53.

[00052] In a particular embodiment of a biliary-type retrieval basket 20 illustrated in FIG. 1A, the tubular tip member 25 is releasable at a predetermined force from the distal ends 24 of the basket wires 21. Referring to FIG. 6B, the tubular tip member 25 may be manufactured from sterling silver. The overall length of the tubular tip member 25 is 0.123 inches and the diameter at the narrowest region 25a is 0.0510 to 0.0520 inches. The inside diameter of the lumen 27 is 0.0352 to 0.0358 inches. The length of the lumen 27 is about 0.086 inches. The distal ends 24 of the basket wires 21 are inserted 0.0545 to 0.688 inches into the lumen 27 of the tubular tip member 25. The diameter of the tubular tip member at the widest region 25b is .085 inches. The distal end 25c of the tubular tip member 25 has a spherico-conical shape to ease cannulation and reduce the risk of trauma to surrounding tissue. The radius of the distal end 25c of the tubular tip member 25 is .030 inches.

[00053] Referring again to FIG. 6A, in one embodiment of the tip joint 25 of the invention, the distal ends 24 of the basket wires 21 are gripped by the tubular member 25 because the tip member 25 is reduced in diameter, i.e. swaged, to cause the wire ends 24 to be compressed together. In other embodiments of the invention, the distal ends 24 of the wires 21 may be joined by adhesives, solder, welding, over-molding, or other means of binding, or by any combination of joining methods, with or without a tubular tip member 25. All of the embodiments of the

WO 02/053037

PCT/US02/00383

- 12 -

distal ends 24 of the wires 21 have in common the feature that the distal ends 24 are releasable when a predetermined force is applied to the tip joint 25 causing the tip joint 25 to become disengaged from the wires 21.

[00054] Referring to FIGS. 7A, 7B, 7C, and 7D, in order to overcome the problems caused  
5 when a component of a medical retrieval device 10 breaks during retrieval of a stone 50 in a body tract, the tip joint 25, according to the invention has an interface which is releasable. By releasing the tip joint 25, the distal ends 24 of the basket wires 21 are freed, i.e. no longer joined together. With the distal ends 24 of the basket wires 21 free, the distal end of the retrieval basket 20 is open, as shown in FIG. 7C. To illustrate this point more clearly, referring to FIG. 7A, the  
10 retrieval basket 20 with captured stone 50 is shown extended beyond the distal end 15 of the sheath 12 in its expanded configuration. The retrieval basket 20 has a releasable tubular member 25 according to the invention.

[00055] Referring now to FIG. 7B, as traction is applied to traction member 40, the basket wires 21 tend to collapse around the stone 50 as the retrieval basket 20 enters the sheath 12. As  
15 an increasing amount of traction is applied to the traction member 40, the basket wires 21 tighten around the stone 50.

[00056] Referring to FIG. 7C, to release the stone 50, an operator applies tension to traction member 40 by pulling on traction member 40 in the proximal direction indicated by the arrow *a*. As basket wires 21 enter the distal end 15 of the sheath 12, a load generated at the tip joint 25 of  
20 the retrieval basket 20 that is less than the load that would cause one or more basket wires 21 to fail or break, but sufficient to cause deformation of the tubular tip member 25. When the tubular tip member 25 deforms, it loosens the grip of the basket wires 21 thereby allowing the distal ends 24 of the basket wires 21 to slide out of the tubular member 25. In one embodiment, the load required to cause the retrieval basket 20 to fail at the tip joint 25 is in the range of about 20  
25 to 50 pounds at the basket tip. In a particular embodiment, the load required to cause the retrieval basket 20 to fail at the tip joint 25 is about 42 pounds.

[00057] Thus, as illustrated in FIG. 7C, the distal ends 24 of the basket wires 21, slide out of tubular member 25 as the retrieval basket 20 is withdrawn further into the sheath 12. The stone 50, illustrated in FIG. 7C, is released from the retrieval basket 20 through the basket distal end.  
30 Referring to FIG. 7D, the retrieval basket 20 is withdrawn further into sheath 12 until the distal ends 24 of the basket wires 21 are retained within the sheath 12. With the basket wires 21 retained by sheath 12, the medical retrieval device 10 can be safely withdrawn from the body

WO 02/053037

PCT/US02/00383

- 13 -

tract.

- [00058] To ensure safe release of the stone 50 in overload conditions during stone retrieval, the retrieval basket distal tip joint 25 fails at a load that is less than the load which would cause any other component in the device 10, such as the traction member 40, to fail. The distal tip joint 25 is strong enough to perform the task for which the device 10 is intended, i.e., stone retrieval or reducing the size of the stone. The design of the device 10 must take the variation in strength of each component and joint of the retrieval device 10 into consideration to ensure that the that the tip joint 25 will fail at a lower load than will any other component or joint of the device 10.
- 10 [00059] FIG. 8 illustrates distribution of forces acting on the distal end 24 of the basket wires 21 restrained by a tip joint such as the tubular tip member 25. Tension, indicated by arrow *a*, on basket wires 21 is resolved into a force component B, indicated by arrow *b* that is aligned with the long axis 26 of the tubular tip member 25 and a force component C indicated by arrow *c* that is at an angle nearly perpendicular to the long axis 26 of the tubular tip member 25. The force component indicated by arrow *b* that is aligned with the long axis 26 of tip member 25 is resisted by the retention force E indicated by arrow *e* generated by the tubular tip member 25 on the basket wires 21. If the force component B aligned with the long axis 26 of the tubular tip member 25 exceeds the available retention force E, the basket wires 21 will slide out of the tubular tip member 25 and release the stone 50.
- 20 [00060] Retention force E, indicated by arrow *e* in FIG. 8, is a result of friction between the basket wires 21 and the tubular tip member 25. The friction between the basket wires 21 and the tubular tip member 25 is influenced by the pressure exerted on the distal ends 24 of the wires 21 by the tubular tip member 25, the surface form of the interior of the tubular tip member 25, the exterior of the basket wires 21, the physical dimensions of the tubular tip member 25, and the distance the distal ends 24 of the basket wires 21 are inserted within the tubular tip member 25. The force component C indicated by arrow *c* that is at an angle nearly perpendicular to the long axis 26 of the tubular tip member 25, acts upon the tubular tip member 25 to reduce the pressure exerted upon the basket wires 21, which reduces the friction and resulting retention force E indicated by arrow *e* in FIG. 8. As the tension A increases, the tubular tip member 25 begins to deform and, as a result, retention force E reduces. If the combined components of the basket wire tension cause the retention force E to be exceeded by the aligned force B, and the total tensile load on the basket wires 21 is less than their failure load, the basket wires 21 will be

WO 02/053037

PCT/US02/00383

- 14 -

released from the tip joint 25.

[00061] The amount of force required to cause tubular tip member 25 to release may also be changed, for example, by varying the crimp length of the tip, varying the thickness of the wall of the tubular region of the tip comprising the crimp, or by scoring the distal ends 24 of the basket wires 21.

5

[00062] Although the description above describes the action of basket wire tension upon a tubular tip member 25, a similar effect can be produced with other methods of joining the basket wires 21 where the forces acting upon the tip joint 25 exceed the strength of the tip joint 25 without exceeding the strength of the basket wires 21. For example, if the basket wires 21 are joined by welding, the weld joint 25 can be designed to fail at a load that is less than the load required to cause the basket wires 21 to fail. Because welding typically causes a localized reduction in the strength of the welded material, such a tip joint 25 can be readily produced.

10

Alternatively, the basket wires 21 may be joined by an adhesive or solder where the mechanical properties of the adhesive or solder material will allow failure of the tip joint 25 at a load that is lower than the failure load of basket wire 21. Alternatively yet, the basket wires 21 may be joined by forming a tip joint 25 around the distal ends 24 of the wires by molding or casting a meltable material such as metal or thermoplastic, or by molding a curable liquid, such as a thermosetting polymer or epoxy around the distal ends 24 of the basket wires 21. The joining method and materials used are dictated largely by the loading requirements of the medical device

15

10. For example, with respect to medical devices intended for simple stone retrieval without lithotripsy, the sheath 12 and retrieval basket 20 are constructed of lighter and more flexible materials to allow easier capture of the stone 50. Because the strength of components comprising such a device is low as compared to devices intended for lithotripsy, the basket wire 21 could be joined at the distal tip joint 25 by adhesive, which would allow release of the stone 50 at a more modest load.

20

25

[00063] FIG. 9 illustrates the design rationale of the medical retrieval device according to the invention including a retrieval basket 20 with a releasable tip joint 25. Curve A illustrates the distribution of basket tip joint 25 failure forces and curve B illustrates the distribution of the failure forces of all other components of the medical retrieval device 10. The distribution of failure forces for basket tip joint 25 is sufficiently lower than the distribution of failure forces for all other components of device 10. Thus, the probability that the basket tip joint 25 strength exceeds the strength of any other component of the device 10 is exceedingly small.

30

WO 02/053037

PCT/US02/00383

- 15 -

[00064] In another aspect of the invention, the medical device 10, including the retrieval basket 20 according to the invention, is used in a method for removing stones 50 from a body tract. The body tract may be any cavity in the body including but not limited to pancreatic ducts, biliary ducts including the hepatic ducts, cystic duct, and common bile duct, ureter, urethra, urinary bladder and kidney.

[00065] Referring again to FIGS. 1A-1C and 7A-7D, in this aspect of the invention, in general, an operator inserts the medical device 10 according to the invention including retrieval basket 20 into the working channel of an endoscope with the retrieval basket 20 in the closed position within sheath 12 as illustrated in FIG. 1A. The medical device 10 alternatively may be passed over a .035 inch guidewire, such as a Jagwire™ guidewire, manufactured by Boston Scientific Corporation of Natick, Massachusetts, using a sidecar 19, through the working channel of the endoscope. Once the device has accessed the body tract of interest, typically an injection of contrast material is made for fluoroscopic visualization. When the retrieval basket 20 approaches the stone or stones 50 to be captured and fragmented, the traction member 40 is advanced distally (in the direction away from the operator) advancing retrieval basket 20 into its expanded configuration where the retrieval basket 20 is no longer restrained by sheath 12. The retrieval basket 20 assumes its expanded configuration outside the distal end 15 of the sheath 12. Then, the operator maneuvers the expanded retrieval basket 20 around stone 50 until stone 50 passes between the basket wires 21 into the retrieval basket 20. Generally, after a stone 50 is captured in the retrieval basket 20, the medical retrieval device 10 including the retrieval basket 20 and captured stone 50 is withdrawn through the body tract. If the combination of the stone 50 and retrieval basket 20 is too large to be withdrawn from the body tract, the stone 50 must be reduced in size or released from the basket 20. To reduce the size of the stone 50 according to the invention, the stone 50 is fragmented by applying traction in the proximal direction to traction member 40 by actuating mechanism 32 forcing basket wires 21 to tighten around stone 50. The degree of force applied to traction member 40 is increased to generate sufficient tension within basket wires 21 to cause the stone 50 to fragment. If additional tension is required to facilitate lithotripsy, the handle 30 may be attached to an Alliance II™ Inflation System, manufactured by Boston Scientific Corporation of Natick, Massachusetts, or to a mechanical lithotripsy system by removing the handle 30 and the sheath 12, and attaching the traction member 40 to the handle of the lithotripsy system. Additional tension may be required when the actuating mechanism 32 in the handle 30 is unable to generate sufficient tension in the basket wires 21, where, for example, the retrieval basket 20 is in almost collapsed position when the

WO 02/053037

PCT/US02/00383

- 16 -

stone 50 is captured because of the small size of the stone 50.

[00066] According to the invention, when the tension needed to fragment the stone 50 approaches the force that would cause any component of the device 10 to fail, the tip joint 25 fails first. In some cases, however, the traction member 40 may fail at the distal end 17 of the handle 30, where, for example, a particular path of the catheter in the patient's body tract results in an increased friction at the proximal end 9 of the traction member 40. If the traction member 40 so fails, a mechanical lithotripsy system can be attached to the traction member 40 by removing the handle 30 and the sheath 12, and attaching the traction member 40 to the handle of the lithotripsy system to provide tension to the basket wires 21 to fragment the stone 50 or achieve the release of the tip joint 25 when the tension needed to fragment the stone 50 approaches the force that would cause any component of the medical device 10 to fail.

[00067] According to one embodiment of the invention, the tip joint 25 fails when the distal ends 24 of basket wires 21 are freed by releasing tubular tip member 25 as illustrated in FIGS. 7C-7D. As the operator applies traction in the proximal direction on the traction member 40, the tubular tip member 25 is released from the distal ends 24 of the basket wires 21 when the force applied to the basket wires 21 through the traction member 40 is less than the force required to cause the basket wires 21 to break, but great enough to cause tubular tip member 25 to deform thereby allowing basket wires 21 to slide out of tubular tip member 25. In one embodiment of the invention, the force required to cause tip member 25 to be released from the distal ends 24 of the basket wires 21 is in the range of about 20 to 50 pounds at the basket tip.

[00068] It will be apparent to those skilled in the art of medical stone retrieval that various modifications and variations can be made to the above-described structure and methodology without departing from the scope or spirit of the invention.

WO 02/053037

PCT/US02/00383

- 17 -

CLAIMS

- 1 1. A medical device for removing objects from a body, comprising:
  - 2 a basket comprising a plurality of wires, the wires comprising a proximal end and
  - 3 a distal end, and
  - 4 a tip joint disposed at the distal end of the basket wires, wherein the tip joint is
  - 5 releasable from the distal ends of the wires when a predetermined force is applied to
  - 6 the tip joint.
- 1 2. The device of claim 1 further comprising:
  - 2 a handle,
  - 3 a sheath extending distally from the handle, the sheath having a lumen extending
  - 4 therethrough from a distal end of the sheath to a proximal end of the sheath, and
  - 5 an elongate traction member axially disposed within the lumen of the sheath, the
  - 6 traction member distally extending from the handle and connected to the proximal end
  - 7 of the basket.
- 1 3. The device of claim 2 wherein the predetermined force is less than the force required to
- 2 cause the traction member or at least one wire of the basket to fail.
- 1 4. The device of claim 1 wherein the tip joint is selected from a group consisting of an
- 2 adhesive joint, a solder joint, a welded joint and an over-molding joint.
- 1 5. The device of claim 3 wherein the tip joint comprises a tubular tip member having a
- 2 distal end, a proximal end, and a lumen extending therethrough, wherein the lumen of the
- 3 tubular tip member is adapted to receive the distal end of the basket therein.
- 1 6. The device of claim 5 wherein the lumen of the tubular tip member is compressed around
- 2 the basket wires thereby securing the distal end of the basket therein.
- 1 7. The device of claim 5 wherein at least one wire of the plurality of wires forming the
- 2 basket is capable of sliding out of the tubular tip member when the predetermined force is
- 3 applied to the tip joint.
- 1 8. The device of claim 5 wherein the tubular tip member deforms at a force that is less than
- 2 the force required to cause the traction member or at least one wire of the plurality of
- 3 wires forming the basket to fail.
- 1 9. The device of claim 8 wherein the tubular tip member is manufactured from a material
- 2 which deforms at a force that is less than the force required to cause the traction member
- 3 or at least one wire of the plurality of wires forming the basket to fail.
- 1 10. The device of claim 8 wherein the tubular tip member is manufactured from a material

WO 02/053037

PCT/US02/00383

- 18 -

- 2 selected from a group consisting of silver-based alloy, silver, gold, platinum, stainless  
3 steel, and nickel titanium alloy.
- 1 11. The device of claim 8 wherein the tubular tip member is manufactured from sterling  
2 silver.
- 1 12. The device of claim 8 wherein the tubular tip member is manufactured from plastics.
- 1 13. The device of claim 8 wherein the force that is less than the force required to cause the  
2 traction member or at least one wire of the plurality of wires forming the basket to fail is  
3 in the range of about 20 pounds to 50 pounds.
- 1 14. The device of claim 2 wherein the traction member is selected from a group consisting of  
2 a cable, a coil, a shaft, a guidewire and a mandril wire.
- 1 15. The device of claim 2 wherein the traction member and the basket are formed from a  
2 single piece of material.
- 1 16. The device of claim 2 wherein the basket wires are joined to the traction member by a  
2 proximal connector.
- 1 17. The device of claim 16 wherein the proximal connector is selected from a group  
2 consisting of an adhesive joint, a solder joint, a welded joint and an over-molding joint.
- 1 18. The device of claim 16 wherein the proximal connector comprises a proximal tubular  
2 member having a distal end, a proximal end, and a lumen extending therethrough,  
3 wherein the lumen of the proximal tubular member is adapted to receive the proximal end  
4 of the basket therein.
- 1 19. The device of claim 18 wherein the lumen of the proximal tubular member is compressed  
2 around the basket wires thereby securing the proximal end of the basket therein.
- 1 20. The device of claim 19 wherein the proximal tubular member is manufactured from  
2 stainless steel.
- 1 21. The device of claim 2 wherein the basket is moveable between a withdrawn position in  
2 which the basket is collapsed within the lumen of the sheath, and an expanded position in  
3 which the basket extends from the distal end of the sheath and is disposed outside of the  
4 lumen for capturing the objects in the body.
- 1 22. The device of claim 21 wherein movement of the basket between the expanded position  
2 and the withdrawn position causes the objects in the body to fragment.
- 1 23. The device of claim 2 wherein the handle comprises at least one actuating mechanism  
2 therein.
- 1 24. The device of claim 2 wherein the traction member is slideably moveable relative to the

WO 02/053037

PCT/US02/00383

- 19 -

- 2 sheath.
- 1 25. The device of claim 2 wherein the traction member is connected to the actuating  
2 mechanism, the actuating mechanism causing the traction member to shift the basket  
3 between the withdrawn position and the expanded position.
- 1 26. The device of claim 2, wherein the sheath is slideably moveable relative to the traction  
2 member.
- 1 27. The device of claim 2 wherein the sheath is connected to the actuating mechanism at the  
2 handle, the actuating mechanism causing the sheath to shift the basket between the  
3 withdrawn position and the expanded position.
- 1 28. The device of claim 1 wherein the plurality of wires comprise stainless steel.
- 1 29. The device of claim 1 wherein the plurality of wires comprise a nickel titanium alloy.
- 1 30. The device of claim 3 wherein the handle is detachable.
- 1 31. The device of claim 3, wherein the sheath is dimensioned to fit within a working channel  
2 of an endoscope.
- 1 32. A method for removing objects from a body tract, comprising the steps of:  
2 providing a medical device comprising:  
3 a handle,  
4 a sheath extending distally from the handle, the sheath having a lumen  
5 extending therethrough from a distal end of the sheath to a proximal end of  
6 the sheath, the sheath is dimensioned to fit within a working channel of an  
7 endoscope,  
8 a basket comprising a plurality of wires, the wires comprising a proximal end  
9 and a distal end, the basket moveable between a withdrawn position in  
10 which the basket is collapsed within the lumen of the sheath, and an  
11 expanded position in which the basket extends from the distal end of the  
12 sheath and is disposed outside of the lumen for capturing the objects in the  
13 body, and  
14 a tip joint disposed at the distal end of the basket wires, wherein the tip joint is  
15 releasable from the distal ends of the wires when a predetermined force is  
16 applied to the tip joint;  
17 introducing the medical device with the basket in the withdrawn position into the  
18 working channel of the endoscope;  
19 accessing the target body tract;

WO 02/053037

PCT/US02/00383

- 20 -

- 20 shifting the basket into the expanded position;  
21 manipulating the basket to capture the objects therein; and  
22 withdrawing the medical device from the body tract.
- 1 33. The method of claim 32, wherein the medical device further comprises an elongate  
2 traction member axially disposed within the lumen of the sheath.
- 1 34. The method of claim 32, wherein the predetermined force is less than the force required  
2 to cause the traction member or at least one wire of the basket to fail.
- 1 35. The method of claim 32, further comprising the step of applying traction to the traction  
2 member in the proximal direction thereby generating tension within the basket and  
3 causing the captured objects to fragment.
- 1 36. The method of claim 32, further comprising the step of applying traction to the sheath in  
2 the distal direction thereby generating tension within the basket and causing the captured  
3 objects to fragment.
- 1 37. The method of claim 32, further comprising the step of injecting contrast material for  
2 fluoroscopic visualization.

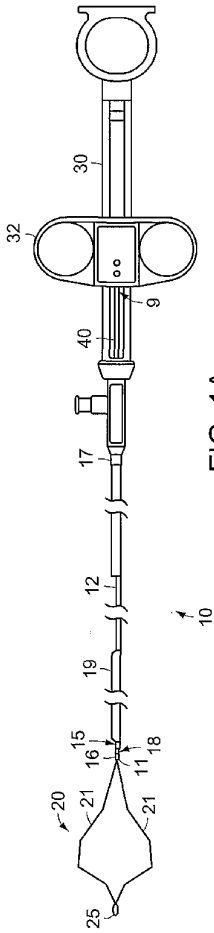

FIG. 1A

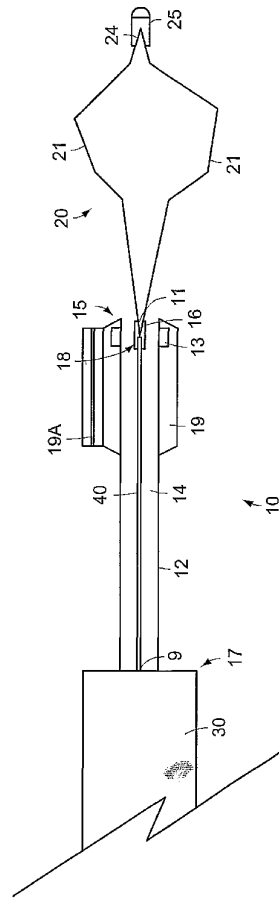

FIG. 1B

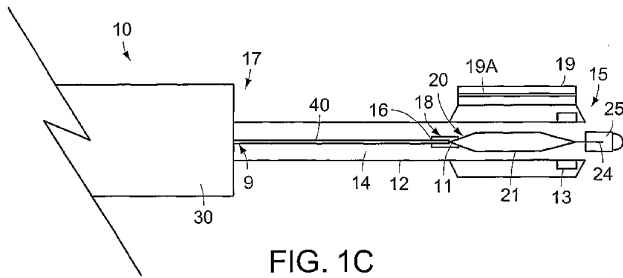

FIG. 1C

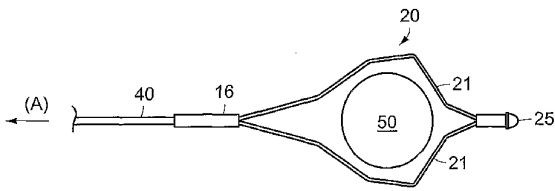

FIG. 2

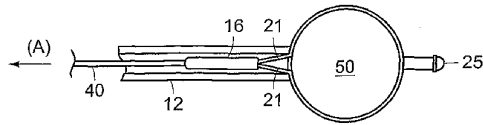

FIG. 3

SUBSTITUTE SHEET (RULE 26)

WO 02/053037

PCT/US02/00383

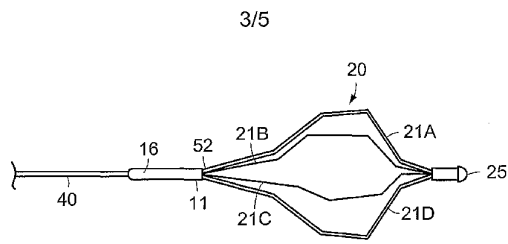

FIG. 4



FIG. 5A

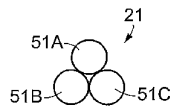

FIG. 5B

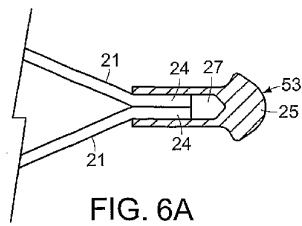

FIG. 6A

SUBSTITUTE SHEET (RULE 26)

4/5

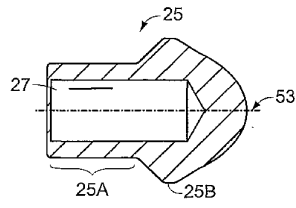

FIG. 6B

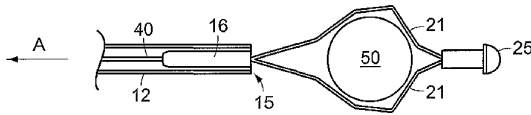

FIG. 7A

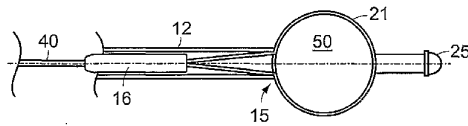

FIG. 7B

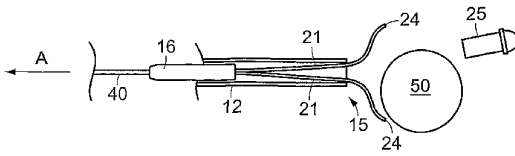

FIG. 7C

SUBSTITUTE SHEET (RULE 26)

WO 02/053037

PCT/US02/00383

5/5

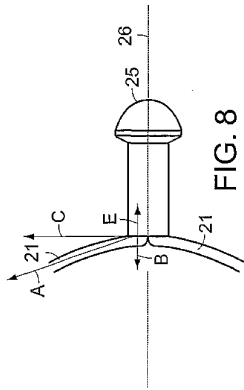

FIG. 8

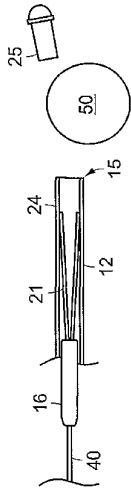

FIG. 7D

SUBSTITUTE SHEET (RULE 26)

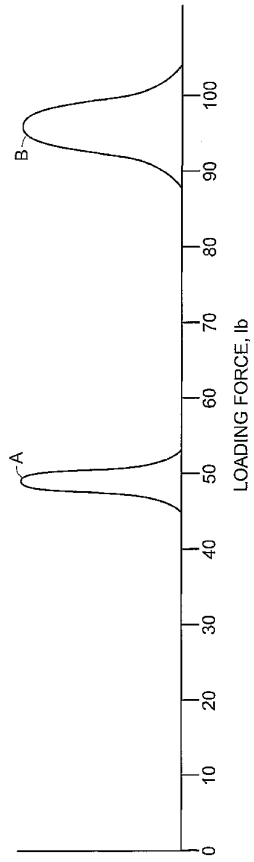

FIG. 9

## 【国際公開パンフレット(コレクション)】

(12) INTERNATIONAL APPLICATION PUBLISHED UNDER THE PATENT COOPERATION TREATY (PCT)

(19) World Intellectual Property Organization  
International Bureau(43) International Publication Date  
11 July 2002 (11.07.2002)

PCT

(10) International Publication Number  
WO 02/053037 A3

- (51) International Patent Classification: A61B 17/00 CZ, DE, DK, DM, DZ, FC, FE, ES, FI, GB, GD, GH, GM, GN, IR, HU, IL, IN, IS, JP, KE, KG, KP, KR, KZ, LC, LK, LR, LS, LT, LU, LV, MA, MD, MG, MK, MN, MW, MX, MZ, NO, NZ, OM, PH, PL, PT, RO, RU, SD, SE, SG, SI, SK, SL, TJ, TM, TN, TR, TT, TZ, UA, UG, UZ, VN, YU, ZA, ZW.
- (21) International Application Number: PCT/US02/00383
- (22) International Filing Date: 7 January 2002 (07.01.2002)
- (25) Filing Language: English
- (26) Publication Language: English
- (30) Priority Data: 60/260,299 8 January 2001 (08.01.2001) US
- (71) Applicant: SCIMED LIFE SYSTEMS, INC. [US/US]; One Scimed Place, Maple Grove, MN 55311-1566 (US).
- (84) Designated States (regional): ARIPO patent (GH, GM, KE, LS, MW, MZ, SD, SL, SZ, TZ, UG, ZM, ZW), Eurasian patent (AM, AZ, BY, KG, KZ, MD, RU, TJ, TM), European patent (AT, BE, CH, CY, DE, DK, ES, FI, FR, GB, GR, IE, IT, LU, MC, NL, PT, SE, TR), OAPI patent (BF, BI, CI, CG, CH, CM, GA, GN, GQ, GW, ML, MR, NE, SN, TD, TG).
- (85) Information about Correction: Previous Correction: see PCT Gazette No. 44/2002 of 31 October 2002, Section II
- (88) Date of publication of the international search report: 27 December 2002
- (81) Designated States (national): AE, AG, AL, AM, AT, AU, AZ, BA, BB, BG, BR, BY, BZ, CA, CH, CN, CO, CR, CU, CZ, DE, DK, DM, DZ, FC, FE, ES, FI, GB, GD, GH, GM, GN, IR, HU, IL, IN, IS, JP, KE, KG, KP, KR, KZ, LC, LK, LR, LS, LT, LU, LV, MA, MD, MG, MK, MN, MW, MX, MZ, NO, NZ, OM, PH, PL, PT, RO, RU, SD, SE, SG, SI, SK, SL, TJ, TM, TN, TR, TT, TZ, UA, UG, UZ, VN, YU, ZA, ZW.
- Published: with international search report
- (72) Inventors: REYNOLDS, Robert, 9 Buckhill Road, Northboro, A 01532 (US); RICHARDSON, M. Kevin, 19 Breakneck Hill Road, Hopkinton, MA 01748 (US); BOWEN, Mark, 13 Red Acre Road, Stow, MA 01775 (US).
- (74) Agent: BELOBORODOV, Mark, L., Testa, Hurwitz & Thibault, 119 High Street Tower, 125 High Street, Boston, MA 02110 (US).
- For two-letter codes and other abbreviations, refer to the "Guidance Notes on Codes and Abbreviations" appearing at the beginning of each regular issue of the PCT Gazette.

(54) Title: RETRIEVAL BASKET WITH RELEASABLE TIP

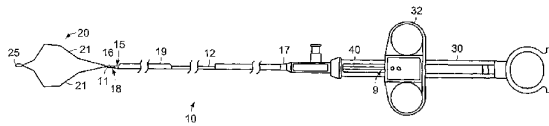

(57) Abstract: A medical retriever device (10) is used to retrieve and/or fragment stones (and/or other objects) from the body of a patient. The device (10) has a retrieval basket (20) with a releasable tip. The tip (25) release (25) is designed to release (25) in a controlled pre-determined manner and under a pre-determined force before any other component of the device fails due to a force exerted on the basket (20).

WO 02/053037 A3

## 【 国際調査報告 】

INTERNATIONAL SEARCH REPORT		International Application No. PCT/US 02/00383
A. CLASSIFICATION OF SUBJECT MATTER IPC 7 A61B17/00 A61B17/22		
According to International Patent Classification (IPC) or to both national classification and IPC		
B. FIELDS SEARCHED		
Minimum documentation searched (classification system followed by classification symbols) IPC 7 A61B		
Documentation searched other than minimum documentation to the extent that such documents are included in the fields searched		
Electronic data base consulted during the international search (name of data base and, where practical, search terms used) EPO-Internal, WPI Data		
C. DOCUMENTS CONSIDERED TO BE RELEVANT		
Category *	Citation of document, with indication, where appropriate, of the relevant passages	Relevant to claim No.
X	WO 99 48429 A (COOK UROLOGICAL INC) 30 September 1999 (1999-09-30)  page 3, line 18-25 page 4, line 24 -page 5, line 5 page 7, line 8-13; figures 10,11 page 14, line 14-23 page 15, line 19 -page 16, line 2; figures 19-21	1,4-6, 14-17, 21,24, 28,29
Y	page 7, line 8-13; figures 19-21	2,18-20, 22,23, 25-27
Y	WO 93 15671 A (ENDOMEDIX CORP) 19 August 1993 (1993-08-19) page 8, line 6 -page 9, line 10; figures 1,14A-14F,18-20	2,23, 25-27
	-/--	
<input checked="" type="checkbox"/> Further documents are listed in the continuation of box C. <input checked="" type="checkbox"/> Patent family members are listed in annex.		
* Special categories of cited documents : *A* document defining the general state of the art which is not considered to be of particular relevance *E* earlier document but published on or after the international filing date *L* document which may throw doubts on priority claim(s) or which is cited to establish the publication date of another citation or other special reason (as specified) *O* document referring to an oral disclosure, use, exhibition or other means *P* document published prior to the international filing date but later than the priority date claimed **T* later document published after the international filing date or priority date and not in conflict with the application but cited to understand the principle or theory underlying the invention *X* document of particular relevance; the claimed invention cannot be considered novel or cannot be considered to involve an inventive step when the document is taken alone *Y* document of particular relevance; the claimed invention cannot be considered to involve an inventive step when the document is combined with one or more other such documents, such combination being obvious to a person skilled in the art. *Z* document member of the same patent family		
Date of the actual completion of the international search 2 September 2002		Date of mailing of the international search report 12/09/2002
Name and mailing address of the ISA European Patent Office, P.O. 5818 Patentlaan 2 NL - 2200 HV Rijswijk Tel: (+31-70) 340-2040, Tx: 31 651 epo nl, Fax: (+31-70) 340-3016		Authorized officer Brumme, I

Form PCT/ISA/210 (second sheet) (July 1992)

## INTERNATIONAL SEARCH REPORT

International Application No PCT/US 02/00383
---

C.(Continuation) DOCUMENTS CONSIDERED TO BE RELEVANT		
Category*	Citation of document, with indication, where appropriate, of the relevant passages	Relevant to claim No.
X	US 6 152 932 A (TERNSTROEM STAFFAN) 28 November 2000 (2000-11-28) column 3, line 16-47; figures 8,14	1
Y	column 7, line 31-54; figures 8,11,14	18-20,22
A	US 6 059 793 A (PAGEDAS ANTHONY C) 9 May 2000 (2000-05-09) column 3, line 61 -column 5, line 65; figures 1-5	1-31
A,P	US 6 264 664 B1 (AVELLANET FRANCISCO J) 24 July 2001 (2001-07-24) the whole document	1-31

Form PCT/ISA/210 (continuation of second sheet) (July 1992)

INTERNATIONAL SEARCH REPORT	national application No. PCT/US 02/00383
<b>Box I Observations where certain claims were found unsearchable (Continuation of item 1 of first sheet)</b>	
This International Search Report has not been established in respect of certain claims under Article 17(2)(a) for the following reasons:	
1. <input checked="" type="checkbox"/>	Claims Nos.: 32-37 because they relate to subject matter not required to be searched by this Authority, namely: Rule 39.1(iv) PCT - Method for treatment of the human or animal body by surgery
2. <input type="checkbox"/>	Claims Nos.: because they relate to parts of the International Application that do not comply with the prescribed requirements to such an extent that no meaningful International Search can be carried out, specifically:
3. <input type="checkbox"/>	Claims Nos.: because they are dependent claims and are not drafted in accordance with the second and third sentences of Rule 6.4(a).
<b>Box II Observations where unity of invention is lacking (Continuation of item 2 of first sheet)</b>	
This International Searching Authority found multiple inventions in this international application, as follows:	
1. <input type="checkbox"/>	As all required additional search fees were timely paid by the applicant, this International Search Report covers all searchable claims.
2. <input type="checkbox"/>	As all searchable claims could be searched without effort justifying an additional fee, this Authority did not invite payment of any additional fee.
3. <input type="checkbox"/>	As only some of the required additional search fees were timely paid by the applicant, this International Search Report covers only those claims for which fees were paid, specifically claims Nos.:
4. <input type="checkbox"/>	No required additional search fees were timely paid by the applicant. Consequently, this International Search Report is restricted to the inventor first mentioned in the claims; it is covered by claims Nos.:
<b>Remark on Protest</b>	
<input type="checkbox"/>	The additional search fees were accompanied by the applicant's protest.
<input type="checkbox"/>	No protest accompanied the payment of additional search fees.

INTERNATIONAL SEARCH REPORT  
Information on patent family members

International Application No  
PCT/US 02/00383

Patent document cited in search report	Publication date	Patent family member(s)	Publication date
WO 9948429	A	30-09-1999	AU 746955 B2 09-05-2002
			AU 3117699 A 18-10-1999
			CA 2323623 A1 30-09-1999
			EP 1063926 A1 03-01-2001
			JP 2002507449 T 12-03-2002
			WO 9948429 A1 30-09-1999
			US 2001041899 A1 15-11-2001
WO 9315671	A	19-08-1993	US 5354303 A 11-10-1994
			WO 9315671 A1 19-08-1993
US 6152932	A	28-11-2000	SE 508742 C2 02-11-1998
			AU 1816997 A 17-10-1997
			EP 0959775 A1 01-12-1999
			JP 2000507856 T 27-06-2000
			SE 9601122 A 26-09-1997
			WO 9735522 A1 02-10-1997
			US 6432111 B1 13-08-2002
US 6059793	A	09-05-2000	US 6258102 B1 10-07-2001
			US 2001002437 A1 31-05-2001
US 6264664	B1	24-07-2001	NONE

## フロントページの続き

(81)指定国 AP(GH,GM,KE,LS,MW,MZ,SD,SL,SZ,TZ,UG,ZM,ZW),EA(AM,AZ,BY,KG,KZ,MD,RU,TJ,TM),EP(AT, BE,CH,CY,DE,DK,ES,FI,FR,GB,GR,IE,IT,LU,MC,NL,PT,SE,TR),OA(BF,BJ,CF,CG,CI,CM,GA,GN,GQ,GW,ML,MR,NE,SN, TD,TG),AE,AG,AL,AM,AT,AU,AZ,BA,BB,BG,BR,BY,BZ,CA,CH,CN,CO,CR,CU,CZ,DE,DK,DM,DZ,EC,EE,ES,FI,GB,GD,GE, GH,GM,HR,HU,ID,IL,IN,IS,JP,KE,KG,KP,KR,KZ,LC,LK,LR,LS,LT,LU,LV,MA,MD,MG,MK,MN,MW,MX,MZ,NO,NZ,OM,PH,PL,PT,RO,RU,SD,SE,SG,SI,SK,SL,TJ,TM,TN,TR,TT,TZ,UA,UG,UZ,VN,YU,ZA,ZW

(72)発明者 リチャードソン, エム. ケビン  
アメリカ合衆国 マサチューセッツ 01748, ホプキントン, ブレイクネック ヒル  
ロード 19

(72)発明者 ボーウェン, マーク  
アメリカ合衆国 マサチューセッツ 01775, ストウ, レッド エーカー ロード 13  
Fターム(参考) 4C060 EE02 EE22

专利名称(译)	带可释放尖端的回收篮		
公开(公告)号	<a href="#">JP2004516880A</a>	公开(公告)日	2004-06-10
申请号	JP2002553990	申请日	2002-01-07
[标]申请(专利权)人(译)	波士顿科学有限公司		
申请(专利权)人(译)	波士顿科技有限公司		
[标]发明人	レイノルズロバート リチャードソンエムケビン ポーウェンマーク		
发明人	レイノルズ, ロバート リチャードソン, エム. ケビン ポーウェン, マーク		
IPC分类号	A61B17/221 A61B17/00 A61B17/22 A61B19/00		
CPC分类号	A61B17/00234 A61B17/221 A61B90/03 A61B2017/00287 A61B2017/2212 A61B2090/037		
FI分类号	A61B17/22.310 A61B17/22.330		
F-TERM分类号	4C060/EE02 4C060/EE22		
优先权	60/260299 2001-01-08 US		
其他公开文献	JP2004516880A5 JP4226327B2		
外部链接	<a href="#">Espacenet</a>		

摘要(译)

使用医学检索装置从患者的身体道（例如胆管和胰管，肝管，胆囊管，胆总管，输尿管，膀胱，尿道和肾）中恢复牙结石（和/或其他物体）和/或片段。该装置具有带可释放尖端的取出篮。芯片的释放以受控和预定的方式实现，并且在任何预定的力下，装置的任何其他部件在由于施加到篮子上的力而发生障碍之前被释放。它被设计成。

